

ALP-4.3

Controller Suite

Application
Programming
Interface

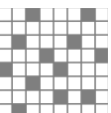

ViALUX Messtechnik + Bildverarbeitung GmbH

Am Erlenwald 10

09128 Chemnitz

Germany

Phone: +49 (0) 371 33 42 47 0

Fax: +49 (0) 371 33 42 47 10

Web: www.vialux.de

E-Mail: dlp@vialux.de

© 2004-2019 ViALUX GmbH. All rights reserved.

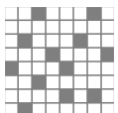

Table of Contents

1	General introduction	1
1.1	ALP Revision Information.....	1
1.2	ALP operation	1
1.3	ALP API files	2
1.4	Return values	3
2	Basic ALP functions	4
2.1	AlpDevAlloc.....	4
2.2	AlpDevControl.....	5
2.3	AlpDevInquire.....	8
2.4	AlpDevControlEx.....	10
2.5	AlpDevHalt	10
2.6	AlpDevFree	11
2.7	AlpSeqAlloc.....	11
2.8	AlpSeqControl	12
2.9	AlpSeqTiming.....	14
2.10	AlpSeqInquire.....	18
2.11	AlpSeqPut	20
2.12	AlpSeqFree	23
2.13	AlpProjControl	24
2.14	AlpProjInquire.....	25
2.15	AlpProjControlEx.....	26
2.16	AlpProjInquireEx	27
2.17	AlpProjStart	28
2.18	AlpProjStartCont	29
2.19	AlpProjHalt	29
2.20	AlpProjWait	30
3	Extended ALP functions.....	30
3.1	Scrolling Extension.....	30
3.2	DMD Mask	32

ALP-4.3 – Application Programming Interface

3.3	Frame Look up Table (FrameLUT)	35
3.4	DMD Area of Interest	37
3.5	AlpSeqPutEx	39
3.6	Sequence Queue Mode	42
3.7	Externally Triggered Frame Transition.....	47
3.8	Flexible PWM Mode	48
3.9	PWM Output.....	52
3.10	Pin assignment and default states	53
3.11	USB Disconnect Handling.....	53
4	LED Control.....	54
4.1	Introduction to the ALP LED API.....	54
4.2	AlpLedAlloc	55
4.3	AlpLedFree.....	57
4.4	AlpLedControl	58
4.5	AlpLedInquire	59
4.6	AlpLedControlEx	60
	AlpLedInquireEx	60
5	Data types, Functions, Constants	61
5.1	Data types	61
5.2	List of Functions	62
5.3	Constant values	65

ALP-4.3 Controller Suite: Application Programming Interface

1 General introduction

1.1 ALP Revision Information

This document summarizes release 21 of the ALP-4.3 application programming interface. It applies to the following file versions:

API DLL file: alp4395.dll 1.0.21.x

API header file (alp.h): 24

1.2 ALP operation

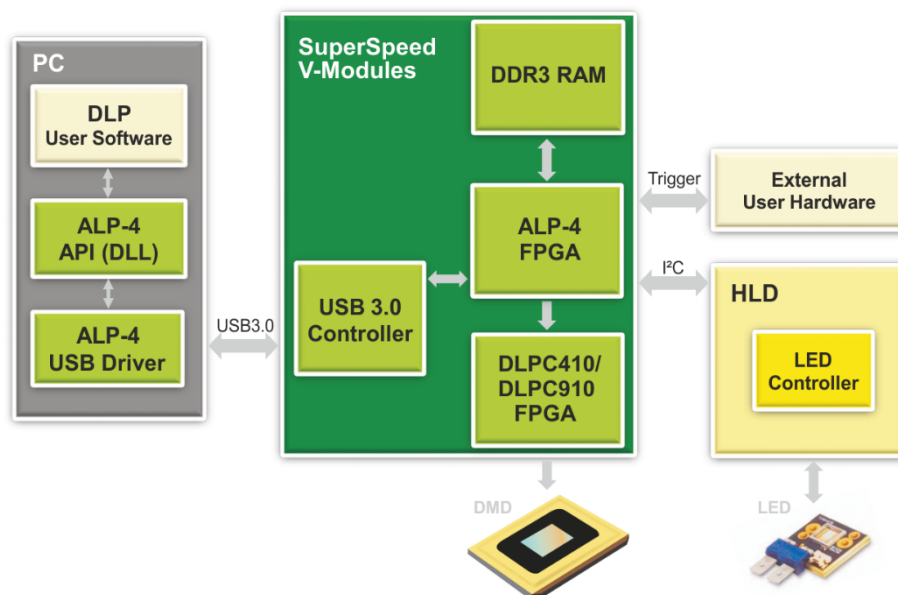

The ALP Controller Suite comes with an application programming interface (API) implemented as a dynamic-link library (DLL). It provides all functions required for the use of ALP hardware components. The following notes describe general software organization rules applicable for the whole library.

- Any ALP is identified by its serial number. Multiple ALP devices can be simultaneously controlled by a single PC.
- The API software provides an ALP device identifier (type `ALP_ID`) for each unit.
- The patterns to be displayed are organized in sequences of 1...32-bit pictures. Any sequence is addressed via a sequence handle (type `ALP_ID`).
- The sequences are loaded into ALP RAM using an API function (`AlpSeqPut`). This RAM is not directly accessible by the user.
- Multi-threading is supported. The library functions serialize critical operations internally.

- *AlpDevHalt* stops ALP operation instantly.
- All functions provide a return value (type long). The parameter list may point to other output data. It is strongly recommended to verify the return value always.
- Various programming samples are available in source code and distributed with the ALP Installation. They provide a quick insight into ALP API programming, and may serve as a template for building a custom application.
- Compatibility is maintained for all ALP-4 API versions running on different controller boards and with different DMD formats; in particular all DLP® V-Modules (V4100, VX4100, V4395, and V4390 models) as well as the DLP Discovery™ 4100 Developer Kits can be controlled with the same software. See Release Notes for version-specific comments.

Please consult the Release Notes for current implementation comments.

Section 2 of this document contains a comprehensive reference of the ALP API functions. Section 3 describes extended options for advanced users, LED driver control is embedded in the ALP-4.3 API and the corresponding LED API reference is given in Section 3.11. Finally Section 5 of this document provides the specification of the interface in case users cannot take advantage of automatic processing of the C header file alp.h.

1.3 ALP API files

The API of ALP-4 consists of a DLL file, an according import library LIB file, and the header file alp.h.

Include alp.h and link the LIB file to your C/C++ application for to use the ALP-4 API. The header declares functions and constant values¹, and the LIB file cares for loading the DLL and imports the API functions when starting your application.

An additional DLL exports the same functions using “standard call” calling convention. It just translates calling conventions, so it depends on the “main” ALP API DLL. This library might be required for development environments that do not support the C calling convention².

¹ When using other programming languages, please read alp.h in a text editor, or refer to chapter 5.

² For more details please search msdn.microsoft.com for “calling conventions”.

	Header file	Import library	Main DLL (C call)	StdCall DLL	Hardware
ALP-4.1	alp.h	alpD41.lib	alpD41.dll	alpD41S.dll	V-9500, V-9600
ALP-4.2	alp.h	alpV42.lib	alpV42.dll	alpV42S.dll	V-7000
ALP-4.3	alp.h	alp4395.lib	alp4395.dll	alp4395S.dll	V-7001, V-9501, V-9601, V-650L, V-6501, V-9001

1.4 Return values

Some return values are commonly used by many of the API functions. This is an explanation of their general meaning.

ALP_OK

The function succeeded.

ALP_PARM_INVALID

One of the parameters is invalid, or a *ControlType* is not supported.

Valid ranges of *ControlValues* may depend on other settings or the device state, so ensure to set up all parameters consistently.

ALP_ADDR_INVALID

Functions that access user data through a pointer parameter (e.g. long **UserVarPtr*) return ALP_ADDR_INVALID when memory access fails. The most probable cause is that this pointer contains an invalid memory address.

ALP_NOT_READY

This return value has different meanings depending on the called function.

AlpDevAlloc: The specified ALP is un-available because it is already allocated.

All functions can return it in multi-threading applications to denote that the ALP is currently in use by another thread.

ALP_NOT_IDLE

To execute the function, the ALP must not display any sequence. Currently the projection loop of *an arbitrary* sequence is running. A concurrent *AlpSeqPut* may also inhibit execution of this function.

ALP_SEQ_IN_USE

There are operations that are mutually exclusive using *the same* sequence. For example, a running projection loop may inhibit writing image data (*AlpSeqPut*) to the same sequence and vice versa.

ALP_NOT_AVAILABLE

All functions having an input parameter *DeviceId* can return this value. The specified *DeviceId* is invalid. Create one using *AlpDevAlloc*.

ALP_ERROR_COMM, ALP_DEVICE_REMOVED

Most of the ALP API functions communicate with the ALP device over the USB. These functions provide the following additional return values when a USB error occurs:

ALP_ERROR_COMM	a communication error occurred during the operation
ALP_DEVICE_REMOVED	the device has been disconnected

USB connection to the device can be checked using *AlpDevInquire*(ALP_USB_CONNECTION). *AlpDevControl*(ALP_USB_CONNECTION) can be used to re-connect to the device after a transient USB interruption.

ALP_ERROR_POWER_DOWN

The DMD has failed to “wake up” from ALP_DMD_POWER_FLOAT mode.

ALP_LOADER_VERSION, ALP_DRIVER_VERSION

A feature is missing in the installed ALP drivers. Update drivers and power-cycle device.

The latest ALP drivers are usually contained in the ALP installation file, available as download from www.vialux.de.

ALP_SDRAM_INIT

SDRAM Initialization failed. Switch off the device and check on-board SO-DIMM.

2 Basic ALP functions**2.1 AlpDevAlloc****Format**

long AlpDevAlloc (long *DeviceNum*, long *InitFlag*, ALP_ID **DeviceIdPtr*)

Description

This function allocates an ALP hardware system (board set) and returns an ALP handle so that it can be used by subsequent API functions.

An error is reported if the requested device is not available or not ready.

When you no longer need a particular ALP system, free it using *AlpDevFree*.

When terminating the ALP system, use *AlpDevFree* before disconnecting it from the USB to avoid problems after USB re-connection.

Parameters

DeviceNum specifies the device to be used. Set this parameter to one of the following values:

ALP_DEFAULT	the next available system is allocated
ALP serial number	the system with the specified serial number is allocated

InitFlag specifies the type of initialization to perform on the selected system. This parameter can be set to one of the following:

ALP_DEFAULT	default initialization
-------------	------------------------

DeviceIdPtr specifies the address of the variable in which to write the ALP device identifier.

Return values

ALP_OK	no errors
ALP_ADDR_INVALID	user data access not valid
ALP_NOT_ONLINE	specified ALP not found
ALP_NOT_READY	specified ALP already allocated
ALP_ERROR_INIT	initialization error
ALP_LOADER_VERSION	Please update ALP drivers and restart the ALP device.

2.2 AlpDevControl

Format

long AlpDevControl (ALP_ID *DeviceId*, long *ControlType*, long *ControlValue*)

Description

This function is used to change the display properties of the ALP. The default values are assigned during device allocation by *AlpDevAlloc*.

Parameters

DeviceId ALP device identifier

ControlType control parameter that is to be modified

ControlValue value of the parameter

The following settings are available:

ControlType	ControlValue	Description
ALP_SYNCH_POLARITY	ALP_LEVEL_HIGH or ALP_DEFAULT	active high frame synch output signal polarity
	ALP_LEVEL_LOW	active low frame synch output signal polarity
ALP_TRIGGER_EDGE	ALP_EDGE_FALLING or ALP_DEFAULT	high to low trigger input signal transition
	ALP_EDGE_RISING	low to high trigger input signal transition
ALP_DEV_DMDTYPE	See “ALP_DEV_DMDTYPE: List of supported DLP chips” below	ALP-4 is available with different DLP chip (DMD types). It detects automatically which DLP chip is connected, so this feature should not be necessary in most cases. For testing purposes, this <i>ControlType</i> can be used to force the API to behave as if another specified DLP chip is connected. See also <i>AlpSeqPut</i> . <i>Note:</i> DMD type selection is accepted only before the first call of <i>AlpSeqAlloc</i> after <i>AlpDevAlloc</i> .
ALP_SEQ_DMD_LINES	MAKELONG(<i>FirstRow</i> , <i>RowCount</i>)	Initializes the Area of Interest, see “DMD Area of Interest” below
ALP_DEV_DMD_MODE	ALP_DMD_POWER_FLOAT	Set the whole DMD to an inactive state. All micro-mirrors are released from deflected to an almost flat (floating) state. Sequence display is not available in this state, but ALP settings and memory are preserved.
	ALP_DMD_RESUME or ALP_DEFAULT	Wake up DMD from inactive state.
ALP_USB_CONNECTION	ALP_DEFAULT	Trigger a re-connect to the device after a temporary USB disconnect.
ALP_USB_DISCONNECT_BEHAVIOUR	ALP_USB_RESET (default), ALP_USB_IGNORE	See “USB Disconnect Handling” below
ALP_PWM_LEVEL	0 to 100 (Percentage)	duty cycle of the PWM pin, see PWM Output below

ALP_DEV_DMDTYPE: List of supported DLP chips

ControlValue	DLP chip	Note
ALP_DMDTYPE_XGA		For compatibility to ALP-3; maps to ALP_DMDTYPE_XGA_07A
ALP_DMDTYPE_XGA_07A	DLP7000	1024x768 pixels
ALP_DMDTYPE_XGA_055X		obsolete
ALP_DMDTYPE_1080P_095A	DLP9500	1920x1080 pixels
ALP_DMDTYPE_WUXGA_096A	DLP9600	1920x1200 pixels
ALP_DMDTYPE_WXGA_S450	DLP650L	1280x800 pixels, S450 package (FYL)
ALP_DMDTYPE_1080P_065A	DLP6500	1920x1080 pixels, Type A package (FLQ)

ALP-4.3 – Application Programming Interface

ALP_DMDTYPE_1080P_065_S600	DLP6500	1920x1080 pixels, S600 package (FYE)
ALP_DMDTYPE_WQXGA_400MHZ_090A	DLP9000X	2560x1600 pixels; standard speed (data clock rate 400MHz); WARNING: DLP9000X requires temperature control of DMD. Refer to DLP9000 data sheet ³ for details and specific limits (standard values of <i>DLP9000FLS</i> , without X).
ALP_DMDTYPE_WQXGA_480MHZ_090A	DLP9000X	2560x1600 pixels; high speed (data clock rate 480MHz); WARNING: DLP9000X requires temperature control of DMD. Refer to DLP9000 data sheet for details and specific limits (tight values of <i>DLP9000XFLS</i>). DLP9000X is initialized in standard speed by default. High speed must be explicitly selected, if required.
ALP_DMDTYPE_DLPC910REV	n/a	<i>AlpDevInquire</i> only. The DMD is not supported by the installed DLPC910 Controller Firmware version. Please contact ViALUX.
ALP_DMDTYPE_DISCONNECT	n/a	<i>AlpDevInquire</i> only. No DMD connected or DMD detection failed.

Return values

ALP_OK	no errors
ALP_NOT_AVAILABLE	the specified ALP identifier is not valid
ALP_NOT_READY	the specified ALP is in use by another function
ALP_NOT_IDLE	the specified ALP is not in idle state
ALP_PARM_INVALID	one of the parameters is invalid
ALP_NOT_ONLINE	the specified ALP was not found (valid return code when <i>ControlType=ALP_USB_CONNECTION</i>)
ALP_NOT_CONFIGURED	The specified ALP might have lost configuration data as a result of a power blackout. The device must be reconfigured using <i>AlpDevFree</i> and <i>AlpDevAlloc</i> .
ALP_ERROR_POWER_DOWN	The DMD has failed to “wake up” from ALP_DMD_POWER_FLOAT mode. This can be caused by a voltage drop during initialization of the DMD. The return code is only valid if <i>ControlType=ALP_DEV_DMD_MODE</i> and <i>ControlValue=ALP_DMD_RESUME</i> .

³ Available at <http://www.ti.com/product/DLP9000> and bundled with ALP-4.3 installation.

2.3 AlpDevInquire

Format

long AlpDevInquire (ALP_ID *DeviceId*, long *InquireType*, long **UserVarPtr*)

Description

This function inquires a parameter setting of the specified ALP device.

Parameter

<i>DeviceId</i>	ALP device identifier for which the information is requested
<i>InquireType</i>	specifies the ALP device parameter setting to inquire; See the table below.
<i>UserVarPtr</i>	specifies the address of the variable in which the requested information is to be written. The variable must be of type long.

The *InquireType* supports the following values:

InquireType	Description
ALP_DEVICE_NUMBER	Serial number of the ALP device
ALP_VERSION	Version number of the ALP device, e.g. 0x4390 for V4390 controller board.
ALP_AVAIL_MEMORY	ALP on-board sequence memory available for further sequence allocation (<i>AlpSeqAlloc</i>) – number of binary pictures; The returned number of binary pictures represents the largest free memory area available for sequence allocation. If ALP memory is fragmented because of repeated calls of <i>AlpSeqAlloc</i> and <i>AlpSeqFree</i> then this value may differ from the total non-allocated memory.
ALP_SYNCH_POLARITY	Frame synch output signal polarity: ALP_LEVEL_HIGH or ALP_LEVEL_LOW
ALP_TRIGGER_EDGE	trigger input signal slope: ALP_EDGE_FALLING or ALP_EDGE_RISING
ALP_DEV_DMDTYPE	write the DMD type to <i>*UserVarPtr</i> . See “ALP_DEV_DMDTYPE: List of supported DLP chips” above. If no DMD is detected (ALP_DMDTYPE_DISCONNECT), then the API emulates a 1080p DMD.
ALP_DEV_DMD_MODE	Write ALP_DMD_POWER_FLOAT or ALP_DMD_RESUME to <i>*UserVarPtr</i> . ALP_DMD_POWER_FLOAT can be entered either by <i>AlpDevControl</i> or by a voltage drop in the primary power supply.

InquireType	Description
ALP_DEV_DISPLAY_HEIGHT	number of mirror rows on the DMD, according to ALP_DEV_DMDDTYPE
ALP_DEV_DISPLAY_WIDTH	number of mirror columns on the DMD, according to ALP_DEV_DMDDTYPE
ALP_USB_CONNECTION	Check, if the USB connection is ok (<i>*UserVarPtr</i> is set to ALP_DEFAULT) or the device is disconnected (<i>*UserVarPtr</i> becomes ALP_DEVICE_REMOVED)
ALP_DDC_FPGA_TEMPERATURE, ALP_APPS_FPGA_TEMPERATURE	ALP-4.2 and ALP-4.3 only: measure the temperature of the DLPC FPGA or Applications FPGA; (see below) The value is written as 1/256 °C to <i>*UserVarPtr</i> . It ranges from -128 °C to +127.96875 °C.
ALP_PCB_TEMPERATURE	ALP-4.2 and ALP-4.3 only: measure the internal temperature of the temperature sensor IC; (see below) The value is written as 1/256 °C to <i>*UserVarPtr</i> . It ranges from -128 °C to +127.75 °C. Accuracy: +/- 3 °C
ALP_PWM_LEVEL	Percentage: duty cycle of the PWM pin, see PWM Output below

Return values

ALP_OK	no errors
ALP_NOT_AVAILABLE	the specified ALP identifier is not valid
ALP_PARM_INVALID	one of the parameters is invalid
ALP_ADDR_INVALID	user data access not valid
ALP_DEVICE_REMOVED	The device has been disconnected.

ALP Temperature Measurement

The ViALUX DLP controller boards (except VX4100) have a temperature sensor IC installed and connected to both FPGAs. The APIs of ALP-4.2 and ALP-4.3 allow reading out the ICs local temperature (ALP_PCB_TEMPERATURE) as well as both FPGA temperatures (ALP_DDC_FPGA_TEMPERATURE, ALP_APPS_FPGA_TEMPERATURE).

Maximum FPGA Temperature: 80 °C.

The API returns a number in a fixed-precision format with 1 LSB=1/256 °C. Just divide **UserVarPtr* by 256 for converting it to a °C scale.

The return value ALP_ERROR_COMM can be caused by disturbance of the on-board I2C bus. A constant value of -128 °C points out conversion problems.

2.4 AlpDevControlEx

Format

long AlpDevControlEx (ALP_ID *DeviceId*, long *ControlType*, void **UserStructPtr*)

Description

Data objects that do not fit into a simple 32-bit number can be written using this function. Meaning and layout of the data depend on the *ControlType*.

Parameters

DeviceId ALP device identifier

ControlType name of the control parameter

UserStructPtr pointer to a data structure whose values shall be send to the device

The following *ControlTypes* are supported:

ControlType	Description
ALP_DEV_DYN_SYNCH_OUT1_GATE, ALP_DEV_DYN_SYNCH_OUT2_GATE, ALP_DEV_DYN_SYNCH_OUT3_GATE	Set up synchronization pins to conditionally output frame synch pulses. See also Gated Frame Synchronization Output. <i>UserStructPtr</i> points to a structure of type <i>tAlpDynSynchOutGate</i> .

Return values

ALP_OK	no error
ALP_NOT_AVAILABLE	the specified ALP identifier is not valid
ALP_NOT_READY	the specified ALP is in use by another function
ALP_PARM_INVALID	one of the parameters is invalid

2.5 AlpDevHalt

Format

long AlpDevHalt (ALP_ID *DeviceId*)

Description

This function puts the ALP in an idle wait state. Current sequence display is canceled (ALP_PROJ_IDLE) and the loading of sequences is aborted (*AlpSeqPut*).

Parameter

DeviceId ALP device identifier

Return values

ALP_OK	no errors
ALP_NOT_AVAILABLE	the specified ALP identifier is not valid

2.6 AlpDevFree**Format**

long AlpDevFree (ALP_ID *DeviceId*)

Description

This function de-allocates a previously allocated ALP device. The memory reserved by calling *AlpSeqAlloc* is also released.

The ALP has to be in idle wait state, see also *AlpDevHalt*.

Parameter

DeviceId ALP identifier of the device to be freed

Return values

ALP_OK	no errors
ALP_NOT_AVAILABLE	the specified ALP identifier is not valid
ALP_NOT_READY	the specified ALP is in use by another function
ALP_NOT_IDLE	the ALP is not in idle state

2.7 AlpSeqAlloc**Format**

long AlpSeqAlloc (ALP_ID *DeviceId*, long *BitPlanes*, long *PicNum*, ALP_ID **SequenceIdPtr*)

Description

This function provides ALP memory for a sequence of pictures. All pictures of a sequence have the same bit depth. The function allocates memory from the ALP board RAM. The user has no direct read/write access. ALP functions provide data transfer using the sequence memory identifier (*SequenceId*) of type ALP_ID.

Pictures can be loaded into the ALP RAM using the *AlpSeqPut* function.

The availability of ALP memory can be tested using the *AlpDevInquire* function.

Sequences are initialized for ALP_BITNUM=12 if *BitPlanes* is more. Default Timing is 30 Hz, if achievable for the selected number of *BitPlanes*.

When a sequence is no longer required, release it using *AlpSeqFree*.

Parameters

<i>DeviceId</i>	ALP device identifier
<i>BitPlanes</i>	bit depth of the patterns to be displayed; ALP supports sequence display of 1 to 12-bit planes in gray-scale mode or 1 to 32 bit planes in ALP_FLEX_PWM mode, see also Flexible PWM Mode below.
<i>PicNum</i>	number of pictures belonging to the sequence; possible values depend upon the available memory (ALP_AVAIL_MEMORY) and the bit depth (<i>BitPlanes</i>)
<i>SequenceIdPtr</i>	specifies the address of the variable in which the ALP sequence identifier is to be written.

Return values

ALP_OK	no errors
ALP_NOT_AVAILABLE	the specified ALP identifier is not valid
ALP_NOT_READY	the specified ALP is in use by another function
ALP_PARM_INVALID	one of the parameters is invalid
ALP_ADDR_INVALID	user data access invalid
ALP_MEMORY_FULL	the memory requested is not available

2.8 AlpSeqControl

Format

long AlpSeqControl (ALP_ID *DeviceId*, ALP_ID *SequenceId*, long *ControlType*, long *ControlValue*)

Description

This function is used to change the display properties of a sequence. The default values are assigned during sequence allocation by *AlpSeqAlloc*.

It is allowed to change settings of sequences that are currently in use. However, the new settings become effective after restart using *AlpProjStart* or *AlpProjStartCont*.

Parameters

<i>DeviceId</i>	ALP device identifier
-----------------	-----------------------

SequenceId ALP sequence identifier
ControlType control parameter that is to be modified
ControlValue value of the parameter

The following settings are available:

ControlType	ControlValue	Description
ALP_SEQ_REPEAT		In the non-continuous mode (<i>AlpProjStart</i>), the projection loop can be configured to execute the sequence projection a certain number of iterations.
	ALP_DEFAULT	single display of the sequence
	<number> 1 ... 1048576	the sequence is displayed this number of times
ALP_FIRSTFRAME ALP_LASTFRAME	<picture number> 0 ... <i>PicNum</i> – 1	a sequence can be displayed partially, the number of the first picture must be equal or lower than the number of the last picture
ALP_BITNUM	<bit number> 1 ... <i>BitPlanes</i>	a sequence can be displayed with reduced bit depth for faster speed; <i>Note:</i> A subsequent call of <i>AlpSeqTiming</i> is necessary, to adjust the sequence timing and to make the new bit depth effective. Until then the timing will not change.
ALP_BIN_MODE		In the binary mode (<i>ALP_BITPLANES</i> = 1 or <i>ALP_BITNUM</i> = 1) this control type can be used to adjust sequence display to have no dark phase between successive pictures. <i>Note:</i> This function has an impact on other timing settings. A subsequent call of <i>AlpSeqTiming</i> is necessary to maintain consistent sequence timing. The new mode becomes effective after this <i>AlpSeqTiming</i> call.
	ALP_BIN_NORMAL or ALP_DEFAULT	Normal operation with programmable dark phase
	ALP_BIN_UNINTERRUPTED	Operation without dark phase (<i>ALP_OFF_TIME</i> =0)
ALP_DATA_FORMAT		Different formats are available for the image data. See also <i>AlpSeqPut</i> for more information.
	ALP_DATA_MSB_ALIGN or ALP_DEFAULT	The gray value of a pixel is stored in one byte. The most significant bit plane is stored in bit 7 of each byte.
	ALP_DATA_LSB_ALIGN	The gray value of a pixel is stored in one byte. The least significant bit plane is stored in bit 0 of each byte.
	ALP_DATA_BINARY_TOPDOWN	Each bit plane is stored in its contiguous memory area, row 0 first.

ControlType	ControlValue	Description
	ALP_DATA_BINARY_BOTTOMUP	Each bit plane is stored in its contiguous memory area, row 0 last.
ALP_SEQ_PUT_LOCK	ALP_DEFAULT	Usually image data of a sequence are protected against writing (<i>AlpSeqPut</i>) during display.
	Not ALP_DEFAULT	Unlock sequence and allow starting of <i>AlpSeqPut</i> concurrently with sequence display. <i>Note:</i> This will likely cause transient image distortion.
ALP_SCROLL_FROM_ROW, ALP_SCROLL_TO_ROW, ALP_FIRSTLINE, ALP_LASTLINE, ALP_LINE_INC	See Scrolling Extension	
ALP_FLUT_MODE, ALP_FLUT_ENTRIES9, ALP_FLUT_OFFSET9	See extension: Frame Look up Table (FrameLUT)	
ALP_SEQ_DMD_LINES	MAKELONG(<i>FirstRow</i> , <i>RowCount</i>)	Selects the Area of Interest for a sequence, see “DMD Area of Interest” below. A call to <i>AlpSeqTiming</i> is necessary for activation.
ALP_PWM_MODE	See extension: Flexible PWM Mode	
ALP_DMD_MASK_SELECT	See extension: DMD Mask	

Return values

ALP_OK	no errors
ALP_NOT_AVAILABLE	the specified ALP identifier is not valid
ALP_NOT_READY	the specified ALP is in use by another function
ALP_PARM_INVALID	one of the parameters is invalid

2.9 AlpSeqTiming

Format

long AlpSeqTiming (ALP_ID *DeviceId*, ALP_ID *SequenceId*, long *IlluminateTime*,
long *PictureTime*, long *SynchDelay*, long *SynchPulseWidth*,
long *TriggerInDelay*)

Description

This function controls the timing properties of the sequence display. Default values are assigned during sequence allocation (*AlpSeqAlloc*).

All timing parameters as well as some of their limits can be inquired using the *AlpSeqInquire* function.

Note: It is allowed to change settings of sequences that are currently in use. However, the new settings become effective after restart using *AlpProjStart* or *AlpProjStartCont*.

Parameters

DeviceId ALP device identifier

SequenceId ALP sequence identifier

IlluminateTime duration of the display of one picture in the sequence

ALP_DEFAULT	The sequence is displayed with the highest possible contrast available for the specified <i>PictureTime</i> .
<microseconds>	Time during that a single picture of the sequence is displayed; if the value is too small then ALP_DEFAULT is effective.

PictureTime time between the start of two consecutive pictures (i.e. this parameter defines the image display rate)

ALP_DEFAULT	If <i>IlluminateTime</i> is also ALP_DEFAULT then 33334 µs are used according to a frame rate of 30 Hz. Otherwise <i>PictureTime</i> is set to minimize the dark time according to the specified <i>IlluminateTime</i> .
<microseconds>, up to 10 ⁷ µs=10 s	If the value is too small then <i>AlpSeqTiming</i> returns ALP_PARM_INVALID.

SynchDelay specifies the time between start of the frame synch output pulse and the start of the display (master mode).

ALP_DEFAULT	0
<microseconds> 0...130,000	delay of the display starts with respect to the trigger output (master mode)

SynchPulseWidth specifies the duration of the frame synch output pulse.

ALP_DEFAULT	= <i>SynchDelay</i> + <i>IlluminateTime</i> in normal mode, that is the pulse finishes at the same time as Illumination = ½ * ALP_ILLUMINATE_TIME (if sequence is set to binary uninterrupted mode)
<microseconds> 1...max	length of the trigger signal, the maximum value is ALP_PICTURE_TIME

TriggerInDelay specifies the time between the incoming trigger edge and the start of the display (slave mode).

ALP_DEFAULT	0
<microseconds> 0 ... 130,000	delay of the start of the display with respect to the trigger input signal (slave mode)

Additional constraints for timing parameters (details are below):

$$PictureTime - IlluminateTime \geq \Delta t_1$$

$$SynchDelay \leq PictureTime - IlluminateTime - 2\mu s$$

$$SynchPulseWidth \leq PictureTime - TriggerInDelay - 1\mu s$$

DMD type	Minimum Dark Phase Δt_1
XGA types	44 μs
1080p (DLP9500)	56 μs
1080p (DLP6500)	97 μs
WXGA	93 μs
WUXGA	61 μs
WQXGA	90 μs (standard speed), 77 μs (high speed)

Notes and Limitations: IlluminateTime and PictureTime

The *PictureTime* is the most important parameter for controlling frame rate. It defines an interval that contains the actual display of one frame as well as all related trigger and synch processing.



The frame display processing is done during a part of *PictureTime* called *IlluminateTime*. Afterwards it takes some time to initialize the next frame. During this time the DMD is cleared. This so-called dark phase determines the minimum difference Δt_1 between *IlluminateTime* and *PictureTime*; that is, $PictureTime - IlluminateTime \geq \Delta t_1$ (see the table above). The default value (ALP_DEFAULT) can be used for *IlluminateTime* or *PictureTime*. If *IlluminateTime* is invalid then it is handled like ALP_DEFAULT.

In the binary mode without dark phase (ALP_BIN_UNINTERRUPTED) the processing of a frame completes when it appears on the DMD. So, in this mode the *IlluminateTime* is ignored.

Minimum values for *IlluminateTime* and *PictureTime* depend on the DMD type, ALP_BITNUM, and ALP_BIN_MODE. They can be inquired using *AlpSeqInquire*.

Notes and Limitations: Synch timing in ALP_MASTER mode

As mentioned above, the complete synchronization output processing of a frame has to happen within its *PictureTime* interval. In master mode, the ALP displays frames and produces synch pulses solely based on internal timing. The *TriggerInDelay* setting is ignored.

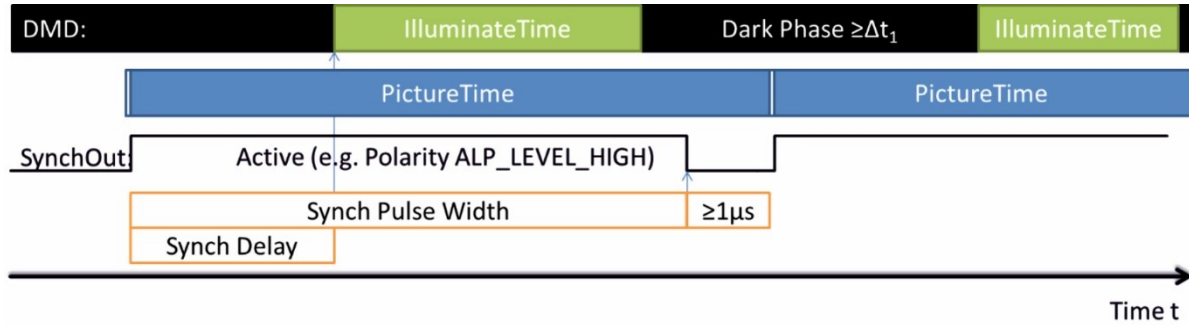

The synch pulse starts at the beginning of *PictureTime* and stops after *SynchPulseWidth*. If the pulse width is not specified (ALP_DEFAULT) then the pulse finishes at the end of illumination. When using ALP_BIN_UNINTERRUPTED mode, the default *SynchPulseWidth* is half of *PictureTime*.

Illumination is delayed from the beginning of the *PictureTime* interval by *SynchDelay*, which is 0 μs by default. Frame display must be completed until 2 μs before *PictureTime* elapses. So, there is a limit: *SynchDelay* ≤ *PictureTime* - *IlluminateTime* - 2μs. This limit can be inquired after *AlpSeqTiming* (with ALP_DEFAULT as Synch and Trigger Delay) using *AlpSeqInquire* (ALP_MAX_SYNCH_DELAY).

Notes and Limitations: Synch timing in ALP_SLAVE mode

In slave mode the timer is paused at the beginning of the *PictureTime* interval. The ALP waits until it detects the selected edge (ALP_TRIGGER_EDGE) at the trigger input.

Then the timer continues and, after *TriggerInDelay* elapses, it starts the illumination. The frame synch output pulse is started simultaneously and the *SynchDelay* setting is ignored in slave mode.

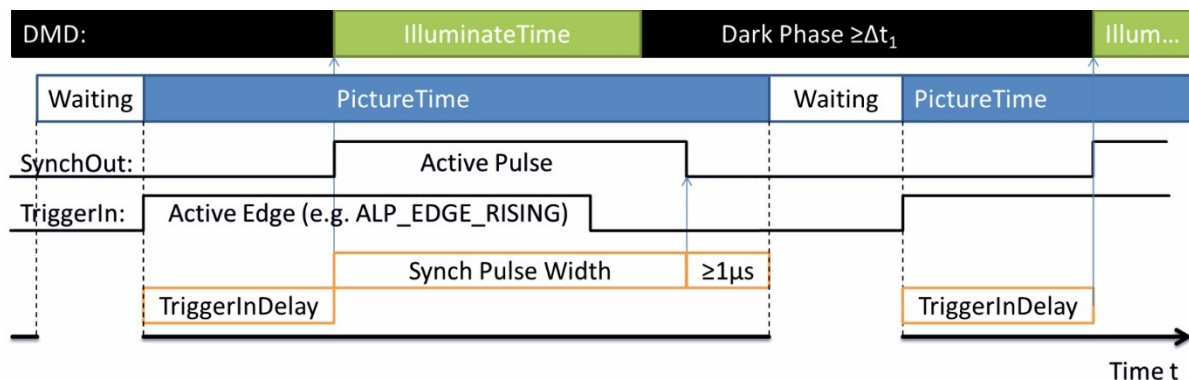

SynchPulseWidth is evaluated even in slave mode, but it can also be ALP_DEFAULT in order to finish the frame synchronization pulse at the end of illumination.

The ALP API allows changing ALP_PROJ_MODE between *AlpSeqTiming* and *AlpProjStart*. That's why it has to enforce consistent parameters for ALP_MASTER and ALP_SLAVE mode. This leads to another constraint: $SynchPulseWidth \leq PictureTime - TriggerInDelay - 1 \mu s$.

The ALP device becomes ready for the next trigger input edge after *PictureTime* elapses. The trigger period must not fall below *PictureTime*. Otherwise a premature trigger slope will be unnoticed.

V-Modules implement *PictureTime* with an accuracy better than 100 ppm (relative) + 0.5 μs (absolute).

Return values

ALP_OK	no error
ALP_NOT_AVAILABLE	the specified ALP identifier is not valid
ALP_NOT_READY	the specified ALP is in use by another function
ALP_PARM_INVALID	one of the parameters is invalid
ALP_SEQ_IN_USE	the specified sequence is currently in use

2.10 AlpSeqInquire

Format

```
long AlpSeqInquire (ALP_ID Deviceld, ALP_ID Sequenceld, long InquireType,
                  long *UserVarPtr)
```

Description

This function provides information about the settings of the specified picture sequence. The settings are controlled either during allocation (*AlpSeqAlloc*) or using the *AlpSeqControl* and *AlpSeqTiming* functions, respectively.

Note that updated values can be queried for ALP_MIN_PICTURE_TIME and ALP_MIN_ILLUMINATION_TIME immediately after modification of ALP_BITNUM and ALP_BIN_MODE (*AlpSeqControl*). The other timing settings are updated by *AlpSeqTiming*.

Parameters

Deviceld ALP device identifier

Sequenceld ALP sequence identifier

InquireType specifies the sequence parameter setting to inquire.

UserVarPtr specifies the address of the variable in which the requested information is to be written.

The *InquireType* parameter can be set to one of the following values:

InquireType	Description
ALP_BITPLANES	bit depth of the pictures in the sequence
ALP_BITNUM	bit depth for display
ALP_BIN_MODE	sequence display in binary mode
ALP_PICNUM	number of pictures in the sequence
ALP_FIRSTFRAME	number of the first picture in the sequence selected for display
ALP_LASTFRAME	number of the last picture in the sequence selected for display
ALP_FIRSTLINE, ALP_LASTLINE, ALP_SCROLL_FROM_ROW, ALP_SCROLL_TO_ROW, ALP_LINE_INC	Scrolling parameters, see section Scrolling Extension
ALP_SEQ_REPEAT	number of automatically repeated displays of the sequence
ALP_PICTURE_TIME	time between the start of consecutive pictures in the sequence in μs , the corresponding picture rate [fps] = $1,000,000 / \text{ALP_PICTURE_TIME} [\mu\text{s}]$
ALP_MIN_PICTURE_TIME	minimum time between the start of consecutive pictures
ALP_MAX_PICTURE_TIME	maximum time between the start of consecutive pictures
ALP_ILLUMINATE_TIME	duration of the display of one picture in μs
ALP_MIN_ILLUMINATE_TIME	minimum duration of the display of one picture in μs
ALP_ON_TIME	total active projection time
ALP_OFF_TIME	total inactive projection time
ALP_SYNCH_DELAY	delay of the start of picture display with respect to the trigger output (master mode) in μs
ALP_MAX_SYNCH_DELAY	maximal duration of trigger delay in μs
ALP_SYNCH_PULSEWIDTH	duration of the output trigger in μs
ALP_TRIGGER_IN_DELAY	delay of the start of picture display with respect to the trigger input in μs
ALP_MAX_TRIGGER_IN_DELAY	maximal duration of trigger delay in μs
ALP_DATA_FORMAT	currently selected image data format (see also <i>AlpSeqControl</i> , <i>AlpSeqPut</i>)
ALP_SEQ_PUT_LOCK	Protect sequence data against writing (<i>AlpSeqPut</i>) during display.

InquireType	Description
ALP_FLUT_MODE, ALP_FLUT_ENTRIES9, ALP_FLUT_OFFSET9	See section Frame Look up Table (FrameLUT)
ALP_PWM_MODE	See section Flexible PWM Mode
ALP_DMD_MASK_SELECT	See section DMD Mask

Return values

ALP_OK	no errors
ALP_NOT_AVAILABLE	the specified ALP identifier is not valid
ALP_PARM_INVALID	one of the parameters is invalid

2.11 AlpSeqPut

Format

```
long AlpSeqPut (ALP_ID DeviceId, ALP_ID SequenceId, long PicOffset, long PicLoad,
               void *UserArrayPtr)
```

Description

This function allows loading user supplied data via the USB connection into the ALP memory of a previously allocated sequence (*AlpSeqAlloc*) or a part of such a sequence. The loading operation can run concurrently to the display of *other* sequences. Data cannot be loaded into sequences that are currently started for display. *Note:* This protection can be disabled by ALP_SEQ_PUT_LOCK.

The function loads *PicNum* pictures into the ALP memory reserved for the specified sequence starting at picture *PicOffset*. The calling program is suspended until the loading operation is completed.

The ALP API compresses image data before sending it over USB. This results in a virtual improvement of data transfer speed. Compression ratio is expected to vary depending on image data. Incompressible data do not cause overhead delays.

Parameters

<i>DeviceId</i>	ALP device identifier
<i>SequenceId</i>	ALP sequence identifier
<i>PicOffset</i>	Picture number in the sequence (starting at 0) where the data upload is started; the meaning depends upon ALP_DATA_FORMAT. The following values are allowed:

ALP_DEFAULT	0
<picture number>	0...ALP_PICNUM – 1 (ALP_DATA_MSB_ALIGN or ALP_DATA_LSB_ALIGN data format)
<bit plane number>	0...ALP_PICNUM*ALP_BITPLANES – 1 (ALP_DATA_BINARY_TOPDOWN, ALP_DATA_BINARY_BOTTOMUP)

PicLoad

number of pictures that are to be loaded into the sequence memory;
Depending on ALP_DATA_FORMAT the following values are allowed:

ALP_DEFAULT	load a complete sequence
<number of pictures>	1 ... ALP_PICNUM – <i>PicOffset</i> (ALP_DATA_MSB_ALIGN or ALP_DATA_LSB_ALIGN data format)
<number of bit planes>	1 ... ALP_PICNUM*ALP_BITPLANES – <i>PicOffset</i> (ALP_DATA_BINARY_TOPDOWN, ALP_DATA_BINARY_BOTTOMUP)

UserArrayPtr

pointer to the user data to be loaded

Data format

Depending on the ALP_DATA_FORMAT setting (*AlpSeqControl*) the input data *UserArrayPtr* as well as *PicOffset* and *PicLoad* parameters have different meaning.

By default, user supplied image data consist of a number of gray level images. The gray level of a pixel is coded in one byte. The API extracts the bit planes of each image by means of optimized code that is much faster than the USB transfer.

Alternatively, the user supplied image data can consist of a number of binary frames. This allows more flexibility in bit plane addressing and compact data storing.

The DMD type (*AlpDevControl*, ALP_DEV_DMDTYPE) affects the data format by the means of three parameters: Columns, Rows, Stride.

Parameter	Description	XGA	WXGA	1080p	WUXGA	WQXGA
<i>Columns</i>	Number of active mirror columns on the DMD	1024	1280	1920	1920	2560
<i>Rows</i>	Number of active mirror rows on the DMD	768	800	1080	1200	1600
<i>Stride</i>	Number of bytes per row in the binary data format	128	160	240	240	320

The following sections summarize the available data formats.

ALP_DATA_MSB_ALIGN (default)

PicOffset	PicLoad	type of UserArrayPtr
0...PicNum-1	1...PicNum-PicOffset	char unsigned [PicLoad*Rows*Columns] for BitPlanes ≤ 8 (AlpSeqAlloc)
		short unsigned [PicLoad*Rows*Columns] for 9 ≤ BitPlanes ≤ 16

The gray value of the pixel at position x ($0 \dots Columns-1$; 0 = left-most), y ($0 \dots Rows-1$; 0 = top-most) of image $PicOffset+n$ ($n = 0 \dots PicLoad-1$) is read from $UserArrayPtr[n*Columns*Rows+y*Columns+x]$.

Data are aligned at the highest bit position. The alignment of the least significant bit depends upon *BitPlanes* of this sequence.

Example: *BitPlanes* = 6

5	4	3	2	1	0	X	X
---	---	---	---	---	---	---	---

Example: *BitPlanes* = 12

11	10	9	8	7	6	5	4	3	2	1	0	X	X	X	X
----	----	---	---	---	---	---	---	---	---	---	---	---	---	---	---

ALP_DATA_LSB_ALIGN

The Pixel/Byte relation is equal to ALP_DATA_MSB_ALIGN.

Data are aligned at the lowest bit position. The alignment of the most significant bit depends upon *BitPlanes* of this sequence.

Example: *BitPlanes* = 6

X	X	5	4	3	2	1	0
---	---	---	---	---	---	---	---

ALP_DATA_BINARY_TOPDOWN

PicOffset	PicLoad	type of UserArrayPtr
0...PicNum*BitPlanes-1	1...PicNum* BitPlanes-PicOffset	char unsigned [PicLoad*Rows*Stride]

Data are organized in bit planes. One gray-scale image consists of binary weighted bit-planes. They are stored in descending order (MSB first). One-bit plane consists of $Rows*Stride$ bytes, that is 96 KiB (XGA) or about 253 KiB (1080p).

Example: *PicNum* = 2, *BitPlanes* = 5 (see *AlpSeqAlloc*), *PicOffset* = 5, *PicLoad* = 4

Image/Bit Plane	0/4	0/3	0/2	0/1	0/0	1/4	1/3	1/2	1/1	1/0
-----------------	-----	-----	-----	-----	-----	-----	-----	-----	-----	-----

Bit planes consist of strides; each stride contains the data of one row in this bit plane. Each image data byte contains 8 adjacent pixel values; bit 7 is the left-most.

Example: the first two strides of *UserArrayPtr* of an XGA bit plane

DMD mirror column	0	1	...	7	8	...	1023
Row 0: Byte.Bit	0.7	0.6	...	0.0	1.7	...	127.0
Row 1: Byte.Bit	128.7	128.6	...	128.0	129.7	...	255.0

Example: the first two strides of *UserArrayPtr* of a 1080p bit plane

Column	0	1	...	7	8	...	1919
Row 0	0.7	0.6	...	0.0	1.7	...	239.0
Row 1	240.7	240.6	...	240.0	241.7	...	479.0

ALP_DATA_BINARY_BOTTOMUP

This data format differs from ALP_DATA_BINARY_TOPDOWN only in the row alignment. The first image data stride in memory represents the bottom row of DMD mirrors.

Return values

ALP_OK	no errors
ALP_NOT_AVAILABLE	the specified ALP identifier is not valid
ALP_NOT_READY	the specified ALP is in use by another function
ALP_PARM_INVALID	one of the parameters is invalid
ALP_ERROR_COMM	the ALP has been disconnected during the loading operation; loading is incomplete
ALP_SEQ_IN_USE	a display is started of the sequence to be loaded
ALP_HALTED	<i>AlpDevHalt</i> has interrupted the execution of <i>AlpSeqPut</i>
ALP_ADDR_INVALID	user data access invalid

2.12 AlpSeqFree

Format

long AlpSeqFree (ALP_ID *DeviceId*, ALP_ID *SequenceId*)

Description

This function frees a previously allocated sequence. The ALP memory reserved for the specified sequence in the device *DeviceId* is released.

Parameters

<i>DeviceId</i>	ALP device identifier
<i>SequenceId</i>	ALP sequence identifier

Return values

ALP_OK	no error
ALP_NOT_AVAILABLE	the specified ALP identifier is not valid
ALP_NOT_READY	the specified ALP is in use by another function
ALP_NOT_IDLE	the ALP is not in the idle wait state
ALP_SEQ_IN_USE	the sequence specified is currently in use
ALP_PARM_INVALID	one of the parameters is invalid

2.13 AlpProjControl**Format**

long AlpProjControl (ALP_ID *DeviceId*, long *ControlType*, long *ControlValue*)

Description

This function controls the system parameters that are in effect for all sequences. These parameters are maintained until they are modified again or until the ALP is freed. Default values are in effect after ALP allocation. All parameters can be read out using the *AlpProjInquire* function.

This function is only allowed if the ALP is in idle wait state (ALP_PROJ_IDLE), which can be enforced by the *AlpProjHalt* function.

Parameters

<i>DeviceId</i>	ALP device identifier
<i>ControlType</i>	name of the control parameter
<i>ControlValue</i>	value of the control parameter

The following settings are available:

ControlType	ControlValue	Description
ALP_PROJ_MODE	The ALP operation is controlled by triggers. The projection loop waits for a trigger event before the next picture of the sequence is displayed.	
	This <i>ControlType</i> is used to select from an internal or external trigger source. The trigger output is always effective, sending out a pulse for every displayed frame. The ALP must be idle, i.e. not executing a projection loop, for this <i>ControlType</i> .	
	ALP_MASTER or ALP_DEFAULT	internal timing triggers ALP operation
	ALP_SLAVE	the transition of an input port triggers frame display
ALP_PROJ_INVERSION	The gray values of the image pixels can be inverted for projection. The ALP is not required to be idle for this <i>ControlType</i> . But because the effect is asynchronous it cannot be expected to take effect immediately upon change.	

ControlType	ControlValue	Description
	ALP_DEFAULT	normal operation
	not ALP_DEFAULT	reverse dark into bright
ALP_PROJ_UPSIDE_DOWN	The image can be flipped for projection. The ALP is not required to be idle for this <i>ControlType</i> . But because the effect is asynchronous it cannot be expected to take effect immediately upon change.	
	ALP_DEFAULT	normal operation
	not ALP_DEFAULT	flip the pictures upside down
ALP_PROJ_WAIT_UNTIL	The <i>AlpProjWait</i> function blocks program execution until the ALP becomes idle. If sequence timing is adjusted to have a substantially longer <i>PictureTime</i> than <i>IlluminateTime</i> , then there is a remarkable difference between end of illumination and completion of <i>PictureTime</i> of the last frame.	
	ALP_PROJ_WAIT_PIC_TIME (default)	Adjust <i>AlpProjWait</i> to return control after <i>PictureTime</i> is completed.
	ALP_PROJ_WAIT_ILLU_TIME	Adjust <i>AlpProjWait</i> to return after <i>Illumination</i> has finished.
ALP_PROJ_STEP	ALP_DEFAULT ALP_LEVEL_HIGH LOW ALP_EDGE_RISING FALLING	See Externally Triggered Frame Transition

Return values

ALP_OK	no error
ALP_NOT_AVAILABLE	the specified ALP identifier is not valid
ALP_NOT_READY	the specified ALP is in use by another function
ALP_PARM_INVALID	one of the parameters is invalid
ALP_NOT_IDLE	the ALP is not in the idle wait state

2.14 AlpProjInquire

Format

long AlpProjInquire (ALP_ID *DeviceId*, long *InquireType*, long **UserVarPtr*)

Description

This function provides information about general ALP settings for the sequence display.

Parameters

DeviceId ALP device identifier for that the information is inquired

InquireType

property for that the parameter provided. The following values are allowed:

InquireType	Value	Description
ALP_PROJ_MODE	ALP_MASTER or ALP_SLAVE	
ALP_PROJ_STATE	ALP_PROJ_ACTIVE	ALP projection active
	ALP_PROJ_IDLE	no projection active
ALP_PROJ_INVERSION	reverse dark into bright	
ALP_PROJ_UPSIDE_DOWN	flip the pictures upside down	
ALP_PROJ_WAIT_UNTIL	ALP_PROJ_WAIT_PIC_TIME or ALP_PROJ_WAIT_ILLU_TIME: <i>AlpProjWait</i> behavior, see also <i>AlpProjControl</i>	
ALP_FLUT_MAX_ENTRIES9	FrameLUT Size, see also Frame Look up Table (FrameLUT)	
ALP_PROJ_STEP	See Externally Triggered Frame Transition	

UserVarPtr

specifies the address of the variable in which the requested information is to be written

Return values

ALP_OK	no errors
ALP_NOT_AVAILABLE	the specified ALP identifier is not valid
ALP_PARM_INVALID	one of the parameters is invalid
ALP_ADDR_INVALID	user data access invalid

2.15 AlpProjControlEx**Format**

long AlpProjControlEx (ALP_ID *DeviceId*, long *ControlType*, void **UserStructPtr*)

Description

Data objects that do not fit into a simple 32-bit number can be written using this function. These objects are unique to the ALP device, so they may affect display of all sequences.

Meaning and layout of the data depend on the *ControlType*.

Parameters

DeviceId ALP device identifier
ControlType name of the control parameter

UserStructPtr pointer to a data structure whose values shall be send to the device

The following *ControlTypes* are supported:

ControlType	Description
ALP_FLUT_WRITE_9BIT	The FrameLUT entries are sent to the ALP. The required data structure is <i>tFlutWrite</i> , and its members are evaluated according to 9-bit FrameLUT mode. See also Writing the FrameLUT. Note that it is allowed to write the FrameLUT even it is currently in use for sequence display. The application program must guard write and read access as required.
ALP_FLUT_WRITE_18BIT	Same as ALP_FLUT_WRITE_9BIT, but data is evaluated for 18-bit FrameLUT mode.
ALP_DMD_MASK_WRITE	Write DMD mask bits to the device. See also DMD Mask

Return values

ALP_OK	no error
ALP_NOT_AVAILABLE	the specified ALP identifier is not valid
ALP_NOT_READY	the specified ALP is in use by another function
ALP_PARM_INVALID	one of the parameters is invalid

2.16 AlpProjInquireEx

Format

long AlpProjInquireEx (ALP_ID *DeviceId*, long *InquireType*, void **UserStructPtr*)

Description

Data objects that do not fit into a simple 32-bit number can be inquired using this function. Meaning and layout of the data depend on the *InquireType*.

Parameters

DeviceId ALP device identifier

InquireType select which information is to be inquired, and select the data structure of *UserStructPtr*

UserStructPtr pointer to a data structure which shall be filled out by *AlpSeqInquireEx*

The following *InquireTypes* are supported:

InquireType	Description
ALP_PROJ_PROGRESS	Retrieve progress information about active sequences and the sequence queue. The required data structure is <i>tAlpProjProgress</i> . See also Inquire Progress of Active Sequences.

Return values

ALP_OK	no error
ALP_NOT_AVAILABLE	the specified ALP identifier is not valid
ALP_NOT_READY	the specified ALP is in use by another function
ALP_PARM_INVALID	one of the parameters is invalid

2.17 AlpProjStart**Format**

long AlpProjStart (ALP_ID *DeviceId*, ALP_ID *SequenceId*)

Description

A call to this function causes the display of the specified sequence that was previously loaded by the *AlpSeqPut* function. The sequence is displayed with the number of repetitions controlled by ALP_SEQ_REPEAT (once by default). This can be interrupted prematurely using the *AlpProjHalt* function.

The calling program gets control back immediately. Use *AlpProjWait* to synchronize your application if required.

The sequence usage flag (ALP_SEQ_IN_USE) is active for a sequence that is currently selected for display. Data cannot be loaded into this sequence (*AlpSeqPut*) and it cannot be freed. Timing adjustments are active after restart of a sequence.

A transition to the next sequence can take place without any gaps. See also the description of *AlpProjStartCont* for details.

Parameters

DeviceId ALP device identifier
SequenceId ALP sequence identifier of the sequence to be displayed

Return values

ALP_OK	no error
ALP_NOT_AVAILABLE	the specified ALP identifier is not valid
ALP_NOT_READY	the specified ALP is in use by another function
ALP_SEQ_IN_USE	the sequence data are currently loaded (<i>AlpSeqPut</i>)
ALP_PARM_INVALID	one of the parameters is invalid
ALP_ERROR_POWER_DOWN	The DMD is powered down. Call <i>AlpDevControl</i> (ALP_DEV_DMD_MODE, ALP_DMD_RESUME) first.

2.18 AlpProjStartCont

Format

long AlpProjStartCont (ALP_ID *DeviceId*, ALP_ID *SequenceId*)

Description

This function displays the specified sequence in an infinite loop.

The sequence display can be stopped using *AlpProjHalt* or *AlpDevHalt*.

A transition to the next sequence can take place without any gaps, if a sequence display is currently active. Depending on the start mode of the current sequence, the switch happens after the completion of the *last* repetition (controlled by ALP_SEQ_REPEAT, *AlpProjStart*), or after the completion of the *current* repetition (*AlpProjStartCont*). Only one sequence start request can be queued. Further requests are replacing the currently waiting request.

Parameters

DeviceId ALP device identifier

SequenceId ALP sequence identifier of the sequence to be displayed

Return values

ALP_OK	no error
ALP_NOT_AVAILABLE	the specified ALP identifier is not valid
ALP_NOT_READY	the specified ALP is in use by another function
ALP_PARM_INVALID	one of the parameters is invalid
ALP_ERROR_POWER_DOWN	The DMD is powered down. Call <i>AlpDevControl</i> (ALP_DEV_DMD_MODE, ALP_DMD_RESUME) first.

2.19 AlpProjHalt

Format

long AlpProjHalt (ALP_ID *DeviceId*)

Description

This function can be used to stop a running sequence display and to set the ALP in idle wait state ALP_PROJ_IDLE. The running sequence loop is displayed until completion of the current iteration.

This function returns immediately. Use *AlpProjWait* to recognize when the projection is finished.

Parameters

DeviceId ALP device identifier

Return values

ALP_OK	no error
ALP_NOT_AVAILABLE	the specified ALP identifier is not valid

2.20 AlpProjWait**Format**

long AlpProjWait (ALP_ID *DeviceId*)

Description

This function is used to wait for the completion of the running sequence display.

Using this function during the display of an infinite loop (*AlpProjStartCont*) causes the ALP_PARM_INVALID error return value. (This applies to ALP_PROJ_LEGACY mode only. See also Inquire Progress of Active Sequences and Legacy Mode Behavior.)

AlpProjControl can adjust the timing with *ControlType* ALP_PROJ_WAIT_UNTIL.

Parameters

DeviceId ALP device identifier

Return values

ALP_OK	no error
ALP_NOT_AVAILABLE	the specified ALP identifier is not valid
ALP_NOT_READY	the specified ALP is in use by another function
ALP_PARM_INVALID	an infinite projection loop is active

3 Extended ALP functions**3.1 Scrolling Extension**

By default, an ALP sequence is considered as a number *PicNum* of pictures, each having the same extent as the DMD. The ALP shows them as DMD frames in the order according to their location in ALP memory. When instead thinking of the ALP sequence as of one very high picture (*PicNum*DmdHeight* rows), the scrolling extension allows linearly stepping through it by an arbitrary number of rows. In fact, this interpretation transforms the default behavior to a special case having step size=*DmdHeight*.

AlpSeqControl has additional *ControlType* parameters to enable the vertically scrolling display: ALP_SCROLL_FROM_ROW, ALP_SCROLL_TO_ROW, ALP_FIRSTLINE, ALP_LASTLINE, and ALP_LINE_INC.

ControlType and ControlValue	Description
ALP_SCROLL_FROM_ROW, ALP_SCROLL_TO_ROW <line number> 0 ... $DmdHeight*(PicNum-1)$	Consider the whole ALP sequence as one big picture of $PicNum*DmdHeight$ rows, and select the scroll range. ALP_SCROLL_FROM and TO_ROW select the frames displayed on the DMD: The top-most DMD row is always in this range. Note that complete DMD frames are displayed starting at these rows. This is the reason for the valid range of these parameters being limited to one <i>DmdHeight</i> above the bottom edge of the picture.
ALP_FIRSTLINE, ALP_LASTLINE <line number> 0... $DmdHeight - 1$	Define the first and last top-line of the scroll range, related to ALP_FIRSTFRAME and LASTFRAME. This is just another method to specify this range. (Historically the first method, compatible down to ALP-1). <i>Note:</i> The ALP_FIRSTLINE must be 0 when the ALP_FIRSTFRAME is the last frame of the sequence (i.e. ALP_PICNUM-1). The ALP_LASTLINE must be 0 when the ALP_LASTFRAME is the last frame of the sequence.
ALP_LINE_INC <line increment> can be positive or negative	The top row of subsequent DMD frames differs by this ALP_LINE_INC number of lines. A value of 0 is interpreted as full DMD height, e.g. 768 (XGA). Negative values make scrolling start at ALP_SCROLL_TO_ROW.

In positive scrolling mode ($ALP_LINE_INC \geq 0$) the top-most row of the first displayed frame is $ALP_SCROLL_FROM_ROW = ALP_FIRSTLINE + DmdHeight * ALP_FIRSTFRAME$. Each subsequent frame starts ALP_LINE_INC rows lower. Scrolling finishes when the DMDs top-most row is $ALP_SCROLL_TO_ROW = ALP_LASTLINE + DmdHeight * ALP_LASTFRAME$. If the range is not an integer multiple of the step width then $ALP_SCROLL_TO_ROW$ is never exceeded.

Negative scrolling ($ALP_LINE_INC < 0$) behaves similar. Its first frame starts at $ALP_SCROLL_TO_ROW$. The display scrolls up until $ALP_SCROLL_FROM_ROW$ is reached and not exceeded.

Scrolling is disabled by setting ALP_LINE_INC , $ALP_FIRSTLINE$, and $ALP_LASTLINE$ to 0.

Hint: Scroll range parameters must always be consistent, that means $0 \leq ALP_SCROLL_FROM_ROW \leq ALP_SCROLL_TO_ROW \leq DmdHeight * (PicNum - 1)$. If both numbers are to be adjusted, then this condition can generally be achieved by the following sequence: First reset $FROM_ROW = 0$, then set TO_ROW to the required value, finally set $FROM_ROW$.

Example: Scroll through a picture showing “Scrolling Text (3072 rows)”, having $4 * DmdHeight$ rows. Step width is set to $ALP_LINE_INC=384$ (positive, half of XGA DMD), and scroll range is from row 0 to row 2304 ($=3072-768$). This results in the 7 DMD frames presented in the picture below:

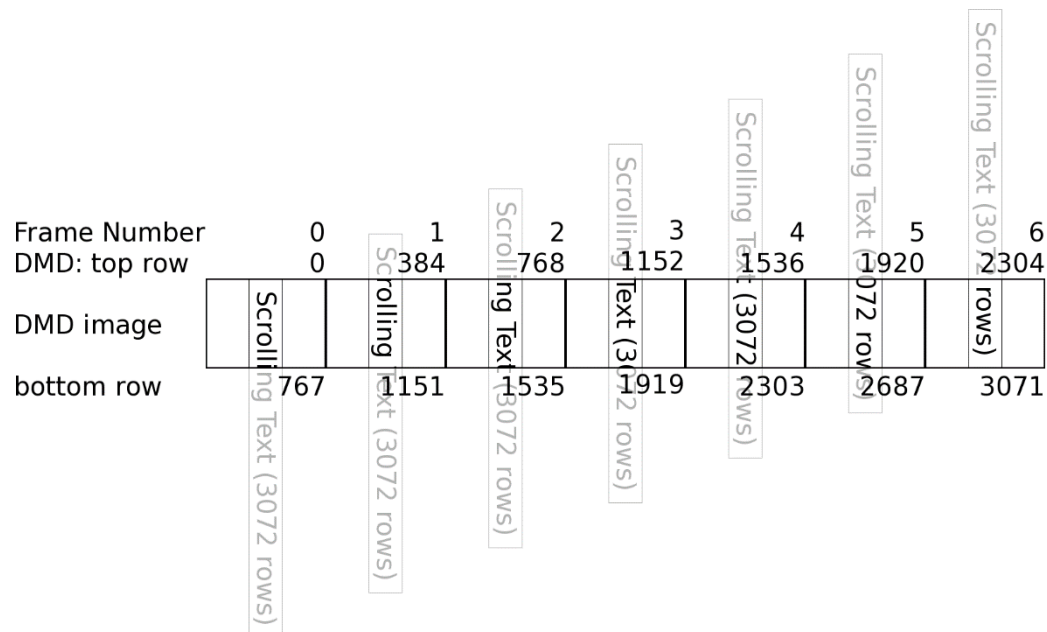

Determine the number of DMD frames by division of scroll range extent + 1 by absolute scroll step, and round up.

Example: XGA DMD, i.e. $DmdHeight=768$ rows, $ALP_SCROLL_FROM_ROW=80$, $ALP_SCROLL_TO_ROW=808$, $ALP_LINE_INC=8$. The number of frames shown by this scrolling sequence is: $\lceil (808 - 80 + 1) / 8 \rceil = 92$.

The same applies if ALP_LINE_INC is negative with same step size (-8).

3.2 DMD Mask

The DMD Mask is a monochrome bitmap that overlays ALP frames during sequence display.

Each mask bit controls a block of 16x16 or 16x8 DMD pixels. Value '1' allows sequence data to be displayed in this block, and value '0' forces all these pixels off.

The affected position is fixed on the DMD. This allows for example to horizontally shape the exposure energy when scrolling vertically through an ALP sequence of frames.

ALP uses one global mask per device. This mask is set to all ones during device initialization and can be overwritten using the API function *AlpProjControlEx*.

The DMD mask is disabled for new ALP sequences by default. In order to use it, first enable it by *AlpSeqControl(ALP_DMD_MASK_SELECT)*.

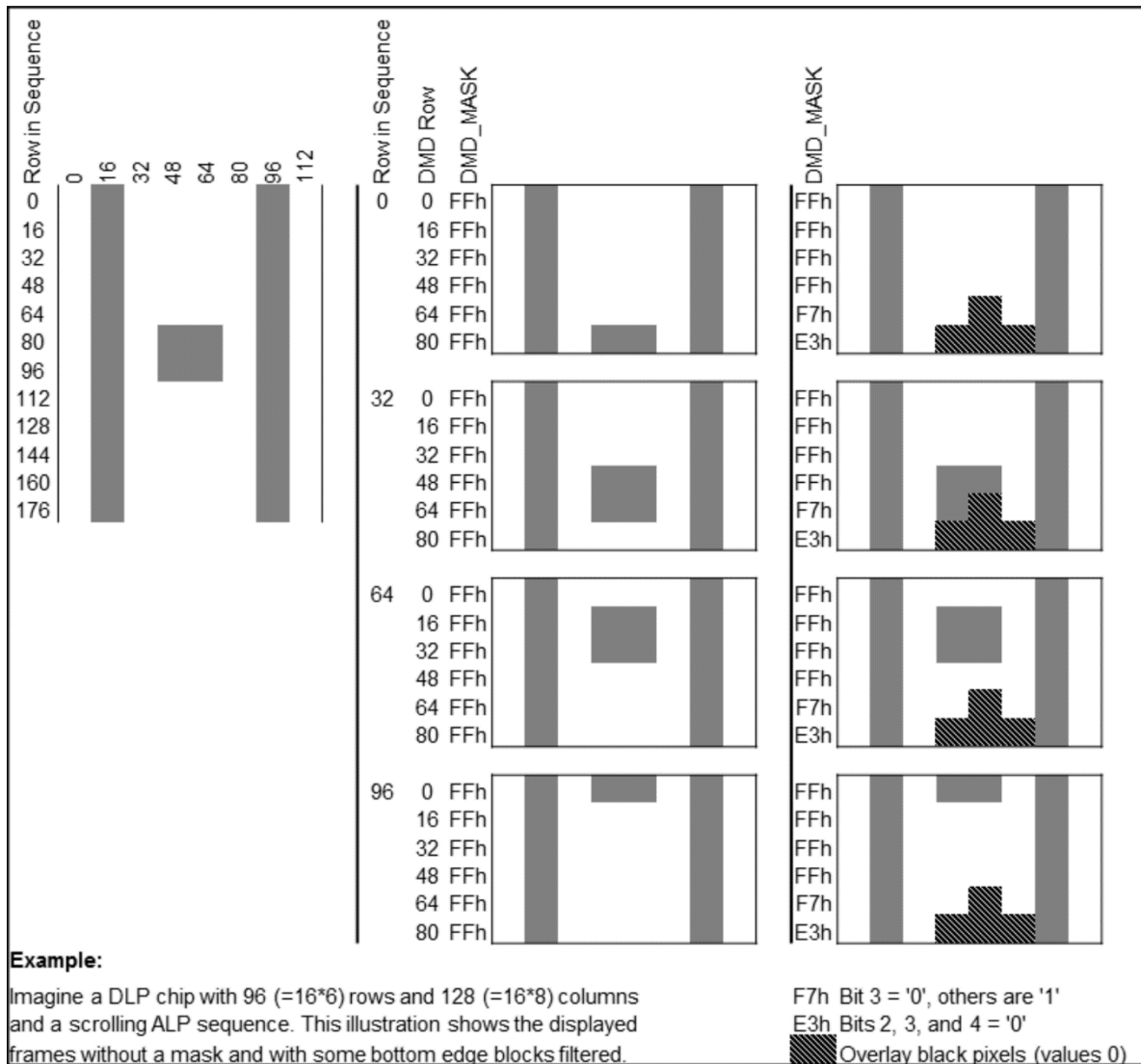

API Functions

Two steps are required for using the DMD Mask: It must be written to the device (AlpProjControlEx) and it must be activated for each sequence as required.

Function (Control/InquireType)	Description
<i>AlpSeqControl/Inquire</i> (ALP_DMD_MASK_SELECT)	Enable the DMD Mask for a given ALP sequence. <i>Control/Value:</i> ALP_DEFAULT, ALP_DMD_MASK_16X16, ALP_DMD_MASK_16X8 16x8 works for XGA and WXGA only.
<i>AlpProjControlEx</i> (ALP_DMD_MASK_WRITE)	<i>UserStructPtr</i> is the address of a structure of type <i>tAlpDmdMask</i> , see below

```

struct tAlpDmdMask
{
    long nRowOffset;    /* Bitmap position in a 16x16 mask, ALP_DEFAULT=0 */
    long nRowCount; /* rows to be written or ALP_DEFAULT (full DMD 16x16 mask) */
    char unsigned Bitmap[2048]; /* each bit controls a block of DMD pixels */
};

```

The Bitmap consists of a number of rows, each MaskStride bytes long. The first byte of each Bitmap row controls the leftmost 8 blocks of the mask row. Bit order is most-significant bit first, i.e. bit 7 to 0 is left to right.

Parameter	Description	XGA	WXGA	1080p	WUXGA	WQXGA
MaskWidth	Columns of Mask Blocks	64	80	120	120	160
MaskStride	Bytes per Mask Row	8	10	15	15	20
MaskHeight	Rows of Mask Blocks 16x16 (16x8, if available)	48 (96)	50 (100)	68 ⁴	75	100
Max Size	Maximum Bytes of the whole Mask 16x16 (16x8)	384 (768)	500 (1000)	1020	1125	2000

Example: the first two mask rows of *Bitmap* for XGA DMD:

DMD mirror column	0..15	16..31	...	112..127	128..143	...	1008..1023
Row 0: Byte.Bit	0.7	0.6	...	0.0	1.7	...	7.0
Row 1: Byte.Bit	8.7	8.6	...	8.0	9.7	...	15.0

The DMD mask can be partially overwritten using the structure members *nRowOffset* and *nRowCount*.

Timing

- ALP_DMD_MASK_SELECT becomes active at the next start of this sequence (*AlpProjStart*, *AlpProjStartCont*).
- ALP_DMD_MASK_WRITE is executed asynchronously. If a sequence runs with DMD mask enabled, then the new mask applies to one of the next frames or even bit planes within a frame.

⁴ the last mask block row only covers 8 DMD pixel rows

- Maximum Frame Rates are not affected by ALP_DMD_MASK_SELECT

3.3 Frame Look up Table (FrameLUT)

Besides the linear display of a sequence, the ALP supports a random-access order via Look up Table. *AlpSeqControl* supports *ControlTypes* to enable FrameLUT mode, and to select the number of frames to be displayed using the look up table. These settings can be adjusted at any time, but they affect display only from the next time, the sequence is started (*AlpProjStart*). There is exactly one FrameLUT in the ALP device, so values are written using *AlpProjControlEx* rather than ALP sequence functions.

FrameLUT is available in two modes: 9-bit mode (ALP_FLUT_9BIT) supports up to ALP_FLUT_MAX_ENTRIES9 values in the range of 0 to 511. Mode ALP_FLUT_18BIT allows values from 0 to $2^{18}-1=262143$, but has only half the size: ALP_FLUT_MAX_ENTRIES9 / 2.

The table below shows related ALP API functions together with their *ControlTypes* and *Values*.

Function (Control/InquireType)	Description
<i>AlpProjInquire</i> (ALP_FLUT_MAX_ENTRIES9)	Inquire the size of the FrameLUT. This function writes the available number of 9-bit values to <i>*UserVarPtr</i> .
<i>AlpSeqControl/Inquire</i> (ALP_FLUT_MODE)	Select whether and how this sequence uses the FrameLUT: ALP_FLUT_NONE (default, linear sequence display), ALP_FLUT_9BIT, or ALP_FLUT_18BIT.
<i>AlpSeqControl/Inquire</i> (ALP_FLUT_ENTRIES9)	1 ... ALP_FLUT_MAX_ENTRIES9 (ALP_DEFAULT: 1) Adjust the number of frames to be displayed in FrameLUT 9-bit mode. There is no according 18-bit parameter: ALP_FLUT_18BIT mode displays ALP_FLUT_ENTRIES9 / 2 frames.
<i>AlpSeqControl/Inquire</i> (ALP_FLUT_OFFSET9)	0 ... ALP_FLUT_MAX_ENTRIES9-1 (ALP_DEFAULT: 0), only integer multiples of 256 are supported Select the part of the FrameLUT used by this sequence.
<i>AlpProjControlEx</i> (ALP_FLUT_WRITE_9BIT), <i>AlpProjControlEx</i> (ALP_FLUT_WRITE_18BIT)	Write entry values to the LUT. In both cases <i>*UserStructPtr</i> points to a structure of type <i>tFlutWrite</i> . But the member values of this structure are interpreted according to the <i>ControlType</i> .

FrameLUT Memory Partitioning

Both FrameLUT modes access the data entries from the same memory. The indexes are mapped as shown in the table below:

Index to FLUT18 (18-bit entries)	Index to FLUT9 (9-bit entries)
0	0
	1
1	2
	3
...	...
2047	4094
	4095

Several sequences can easily share their use of the FrameLUT, as long as the sum of individual `ALP_FLUT_ENTRIES9` does not exceed the available size (`ALP_FLUT_MAX_ENTRIES9`). The `ALP_FLUT_OFFSET9` setting allows selecting which part of the LUT is used by each sequence. It is up to the application program to manage partitions, for example locking parts for exclusive use.

Writing the FrameLUT

AlpProjControlEx supports two *ControlTypes* for that purpose: `ALP_FLUT_WRITE_9BIT` and `ALP_FLUT_WRITE_18BIT`.

Create a variable of type *tFlutWrite* and initialize its contents: *nSize* is the number of FrameLUT entries to be written, *nOffset* selects the destination inside the FrameLUT, and the *FrameNumbers* array contains the actual values of FrameLUT entries.

AlpProjControlEx first checks the valid range ($nSize+nOffset \leq ALP_FLUT_MAX_ENTRIES9$ for `ALP_FLUT_WRITE_9BIT` or $ALP_FLUT_MAX_ENTRIES9 / 2$ for `ALP_FLUT_WRITE_18BIT`; on error: `ALP_PARM_INVALID`).

Then it transfers the least significant 9 or 18 bits of each *FrameNumber* to the FrameLUT: for all *i* in 0 to *nSize*-1: copy *FrameNumbers*[*i*] to `FrameLUT`[*i*+*nOffset*]).

Note: The range of each *FrameNumber* is not validated by ALP. The application program shall limit the values to 9 or 18 bit accordingly. Moreover, the ALP API cannot validate that all values address the allocated sequence memory. This must also be ensured by the application.

All parts of the FrameLUT may be written at any time, even when the ALP displays sequences.

Interaction with Scrolling Parameters

Scrolling parameters and FrameLUT are combined. By default, `ALP_LINE_INC=DmdHeight` resulting in true DMD frames to be addressed by the FrameLUT. Internally the FrameLUT entries are multiplied by `ALP_LINE_INC`. This provides look-up resolution of up to 1 DMD row.

ALP_FIRSTFRAME (or more general: the scroll range, ALP_SCROLL_FROM_ROW) affects display in FrameLUT modes. FrameLUT entry value 0 shows picture ALP_FIRSTFRAME. This allows for example for 9-bit FrameLUT display of the higher part of a sequence of 1024 pictures. It also allows moving through a sequence with always re-using the same FrameLUT access pattern.

DMD frames ($i=0\dots\text{Entries}-1$) are displayed with their top-most row starting from the Sequence Pictures row $\text{ALP_SCROLL_FROM_ROW} + \text{FrameLUT}[i] * \text{ALP_LINE_INC}$.

For negative ALP_LINE_INC the FrameLUT access is based on ALP_SCROLL_TO_ROW.

3.4 DMD Area of Interest

The ALP-4.3 API supports an additional display mode with reduced image data. An Area of Interest (AOI) can be selected by means of contiguous DMD rows.

This feature requires an additional initialization step, and afterwards it supports switching any sequence to this display mode.

3.4.1 Initialization: `AlpDevControl(ALP_SEQ_DMD_LINES)`

Initialize the ALP device for AOI mode with *ControlType*=ALP_SEQ_DMD_LINES and *ControlValue* storing first and last active DMD row in a packed format. For convenience, the windows.h preprocessor macro `MAKELONG(FirstRow, RowCount)` can be used. It results in a 32-bit value with `HIWORD(ControlValue)=RowCount` and `LOWORD(ControlValue)=FirstRow`. The last line is $\text{FirstRow} + \text{RowCount} - 1$.

3.4.2 Execution: `AlpSeqControl(ALP_SEQ_DMD_LINES)`

A previously initialized AOI can be selected for a sequence using *ControlType*=ALP_SEQ_DMD_LINES and *ControlValue* according to the initialized value. An additional *AlpSeqTiming* call is required. Then the AOI mode is active in the next calls to *AlpProjStart[Cont]*.

3.4.3 Limitations

- AOI selection (*AlpSeqControl*) is only supported for a previously initialized AOI (*AlpDevControl*).
- AOI is only supported in binary display mode (`ALP_BITNUM=1`).
- Display steps through sequence data by full DMD frames even in AOI mode. This results in gaps of unused data and thus a waste of ALP sequence memory. Use *AlpSeqControl*(ALP_LINE_INC, *RowCount*) in order to save memory.
- Only up to one AOI is supported. The second call to *AlpDevControl*(ALP_SEQ_DMD_LINES) fails.
- *AlpDevControl*(ALP_SEQ_DMD_LINES) works after *AlpDevAlloc* and only before the first sequence allocation (*AlpSeqAlloc*)

- If *AlpDevControl*(ALP_DEV_DMDTYPE) is required, call it before *AlpDevControl*(ALP_SEQ_DMD_LINES)
- ALP_PROJ_UPSIDE_DOWN should be ALP_DEFAULT when using AOI.

3.4.4 AlpSeqPutEx

Image data using *AlpSeqPut* has transfer units of full DMD size. This behaviour adds complexity when generating data for AOI sequences.

In contrast to that, *AlpSeqPutEx* (*TransferMode*=ALP_PUT_LINES) respects the current AOI settings of a sequence. Full AOI pictures are addressed if *LineOffset* = *LineLoad* = ALP_DEFAULT.

As a consequence, the valid range of *PicLoad* and *PicOffset* increases. If, for example, AOI *RowCount*=ALP_DEV_DISPLAY_HEIGHT/2, then a sequence of 10 full DMD pictures stores 20 AOI pictures. *PicOffset* may range from 0 to 19, and *PicOffset*+*PicLoad* up to 20.

3.4.5 Expected Timing

The first frame of a sequence could be (<2µs)longer than specified

The maximum frame rate of a setting can always be inquired by means of ALP_MIN_PICTURETIME. Please find values for selected areas of interest in the table below (accuracy of minimum picture times better than 0.5 µs).

Minimum picture time is technically limited to 20µs (ALP_BIN_UNINTERRUPTED) or 40µs (ALP_BIN_NORMAL)

V-Module	Full Array lines	Full Array fps	500 lines AOI fps	200 lines AOI fps
V-7001	768	22727	30303	47619
V-9501	1080	17857	30303	47619
V-9601	1200	16393	30303	47619
V-650L	800	10752	15873	30303
V-6501	1080	10309	20000	38461
V-9001 ⁵	1600	12987	32258	50000

⁵ DMD Type ALP_DMDTYPE_WQXGA_480MHZ_090A

3.5 AlpSeqPutEx

Format

```
long AlpSeqPutEx ( ALP_ID DeviceId, ALP_ID SequenceId, void *UserStructPtr,
                  void *UserArrayPtr)
```

Description

Image data transfer using *AlpSeqPut* is based on whole DMD frames. Applications that only update small regions inside a frame suffer from overhead of this default behavior. An extended ALP API function is available to reduce this overhead.

The *AlpSeqPutEx* function offers the same functionality as the standard function (*AlpSeqPut*), but in addition, it is possible to select a section within a sequence frame using the *LineOffset* and *LineLoad* parameters of the *tAlpLinePut* data-structure (see below) and update only this section of the SDRAM-memory associated with the sequence for a range of sequence-pictures (selected via the *PicOffset* and *PicLoad* parameters of *tAlpLinePut* in similarity to *AlpSeqPut*).

This results in accelerated transfer-time of small image data updates (due to the fact that the amount of transferred data is reduced).

Therefore, the user only passes the lines of the pictures he wants to update via the *UserArrayPtr* (that would be *PicLoad*LineLoad* lines in total).

Parameters

<i>DeviceId</i>	ALP device identifier
<i>SequenceId</i>	ALP sequence identifier
<i>UserStructPtr</i>	Pointer to the <i>tAlpLinePut</i> -data structure (see below), which contains information about the transferred data
<i>UserArrayPtr</i>	Pointer to the user data to be loaded (has to contain only the data of all lines to be updated one after the other)

Type (size in bytes), Function	Member data type (size)	Member (byte offset)
<i>tAlpLinePut</i> (20), <i>AlpDevControlEx</i>	long (4)	TransferMode (0)
	long (4)	PicOffset (4)
	long (4)	PicLoad (8)
	long (4)	LineOffset (12)
	long (4)	LineLoad (16)

<i>TransferMode</i>	Must be set to ALP_PUT_LINES otherwise ALP_PARM_INVALID is returned
<i>PicOffset</i>	This parameter is interpreted like the <i>PicOffset</i> parameter used in <i>AlpSeqPut</i> . The value of the parameter must be greater or equal to zero otherwise ALP_PARM_INVALID is returned.
<i>PicLoad</i>	This parameter is interpreted like the <i>PicLoad</i> parameter used in <i>AlpSeqPut</i> . If the value of this parameter is smaller than zero or if <i>PicOffset+PicLoad</i> is exceeding the boundary of the sequence-memory, ALP_PARM_INVALID is returned. If the value is zero, the parameter is automatically adjusted to include all pictures of the sequence starting at frame <i>PicOffset</i> .
<i>LineOffset</i>	Defines the offset of the frame-section. The frame-data of this section is transferred for each of the frames selected with <i>PicOffset</i> and <i>PicLoad</i> . The value of this parameter must be greater or equal to zero, otherwise ALP_PARM_INVALID is returned.
<i>LineLoad</i>	Defines the size of the frame-section. If the value of the parameter is less than zero or if <i>LineOffset+LineLoad</i> exceeds the number of lines per sequence-frame, ALP_PARM_INVALID is returned. If <i>LineLoad</i> is zero, this value is adjusted to include all lines of the frame, starting at line <i>LineOffset</i> .

Return values

ALP_OK	no errors
ALP_NOT_AVAILABLE	the specified ALP identifier is not valid
ALP_NOT_READY	the specified ALP is in use by another function
ALP_PARM_INVALID	one of the parameters is invalid
ALP_ERROR_COMM	the ALP has been disconnected during the loading operation; loading is incomplete
ALP_SEQ_IN_USE	a display is started of the sequence to be loaded
ALP_HALTED	<i>AlpDevHalt</i> has interrupted the execution of <i>AlpSeqPutEx</i>
ALP_ADDR_INVALID	user data access invalid

Code-Sample

```

/* This sample-code transfers
5 frames with a section of 100 lines height and an offset
of 50 lines */

ALP_ID DeviceId, SequenceId;
tAlpLinePut AlpLinePut;

// This pointer should point to the image-data
UCHAR* SeqData;

```

```

// Allocate device
AlpDevAlloc( ALP_DEFAULT, ALP_DEFAULT, &DeviceId);

// Allocate a sequence with 5 frames
AlpSeqAlloc(DeviceId, 1, 5, &SequenceId);

// Setting up the Parameters for AlpSeqPutEx
AlpLinePut.TransferMode      = ALP_PUT_LINES;
AlpLinePut.PicOffset        = 0;
AlpLinePut.PicLoad           = 5;
AlpLinePut.LineOffset       = 50;
AlpLinePut.LineLoad         = 100;

// Transfer image-data
AlpSeqPutEx(DeviceId, SequenceId, &AlpLinePut, SeqData);

```

Memory layout of the code-example:

F0 ... F4 referring to the frames of the sequence
R000 ... R767 referring to the 768 lines per frame (e.g. XGA)

Sequence-data passed to
AlpSeqPutEx

F0.R050
...
F0.R149
F1.R050
...
F1.R149
F2.R050
...
F2.R149
F3.R050
...
F3.R149
F4.R050
...
F4.R149

Sequence-data stored
in the SDRAM

F0.R000
...
F0.R050
...
F0.R149
...
F0.R767
F1.R000
...
F1.R050
...
F1.R149
...
F1.R767
F2.R000
...
F2.R050
...
F2.R149
...
F2.R767
F3.R000
...
F3.R050
...
F3.R149
...
F3.R767

F4.R000
...
F4.R050
...
F4.R149
...
F4.R767

3.6 Sequence Queue Mode

Subsequent ALP sequences can be run without any break in between. This requires that a sequence is already waiting for execution while another one is still running. The last frame of the currently running sequence completes its *PictureTime*, and then the waiting sequence immediately starts its first frame.

This means that two sequences having the same timing setup will display flawlessly. But even when changing timing, the synch, trigger, and illumination timing is well defined, see below.

The ALP API can be switched to ALP_PROJ_SEQUENCE_QUEUE mode. In this mode it allows having multiple active sequences. Like in a waiting line each sequence waits until the previous one has finished. Then it starts running automatically. At any given time there can 0 or 1 sequence be *running* in the ALP while 0 to “n” sequences are *waiting*. Both are called *active* sequences.

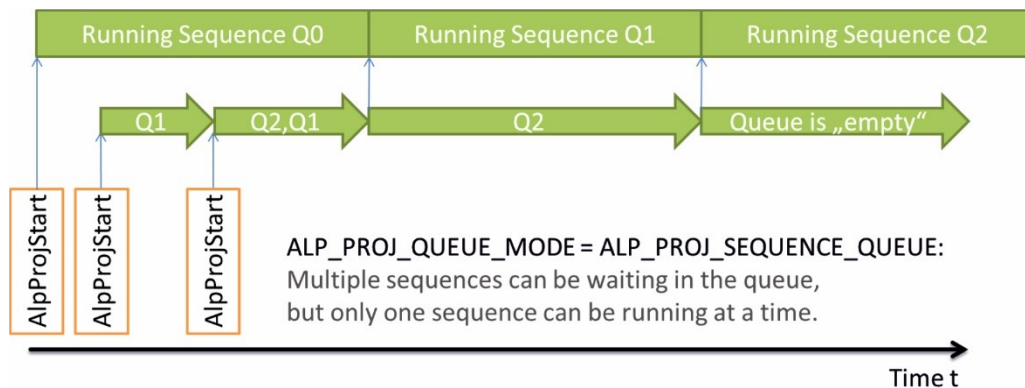

In ALP_PROJ_LEGACY mode (default) the ALP API behaves compatible to previous versions. It emulates 1 waiting position with some special behavior, see below.

Related API Controls

The table below shows Sequence Queue related ALP API functions together with their *ControlTypes* and *Values*.

Function (Control/InquireType)	Description
<i>AlpProjControl</i> (ALP_PROJ_QUEUE_MODE), <i>AlpProjInquire</i> (ALP_PROJ_QUEUE_MODE)	Switch between ALP_PROJ_LEGACY (default) and ALP_PROJ_SEQUENCE_QUEUE mode. This is only allowed when the ALP is idle (no sequence active).

<i>AlpProjInquire</i> (ALP_PROJ_QUEUE_AVAIL)	Inquire how much space is free in the queue.
<i>AlpProjInquire</i> (ALP_PROJ_QUEUE_MAX_AVAIL)	Inquire the whole size of the Sequence Queue.
<i>AlpProjStart</i> (called in Queue Mode)	<p>Activate a sequence for finite iterations. This sequence will run until its regular end according to its ALP_SEQ_REPEAT, or until aborted.</p> <p>If no sequence is currently running, then the new sequence starts immediately. Else it is enqueued and waits.</p> <p>This function can return ALP_MEMORY_FULL if there is no space available in the queue.</p>
<i>AlpProjStartCont</i>	Similar to <i>AlpProjStart</i> , but activate the sequence for indefinite iterations. Once started, it will run until aborted.
<i>AlpProjInquire</i> (ALP_PROJ_QUEUE_ID)	Provide the <i>QueueID</i> (ALP_ID) of the most recently enqueued sequence (or ALP_INVALID_ID, if <i>AlpProjStart[Cont]</i> has not yet been called since <i>AlpDevAlloc</i>)
<i>AlpProjControl</i> (ALP_PROJ_ABORT_SEQUENCE)	Abort an active sequence at the end of a repetition (after ALP_LASTFRAME). <i>ControlValue</i> can be ALP_DEFAULT or a <i>QueueID</i> . See below.
<i>AlpProjControl</i> (ALP_PROJ_ABORT_FRAME)	Abort an active sequence after the next frame (not necessarily ALP_LASTFRAME). See below.
<i>AlpProjControl</i> (ALP_PROJ_RESET_QUEUE)	Remove all waiting sequences from the queue. The currently running sequence is not affected. <i>ControlValue</i> must be ALP_DEFAULT.
<i>AlpProjHalt</i>	Same as ALP_PROJ_RESET_QUEUE followed by ALP_PROJ_ABORT_SEQUENCE.
<i>AlpProjWait</i>	Wait until device is idle. Note that in Sequence Queue Mode it is allowed to concurrently activate or abort sequences. See below for details.
<i>AlpProjInquireEx</i> (ALP_PROJ_PROGRESS)	Inquire detailed progress information of the running sequence and the queue. See below.

Abort and Reset: Influence Active Sequences

There are situations when a premature abort of an active sequence is desirable. For example, in Sequence Queue Mode, a continuous sequence can be followed by other sequences. These sequences would wait forever, because the first one has no regular end.

ALP-4.3 – Application Programming Interface

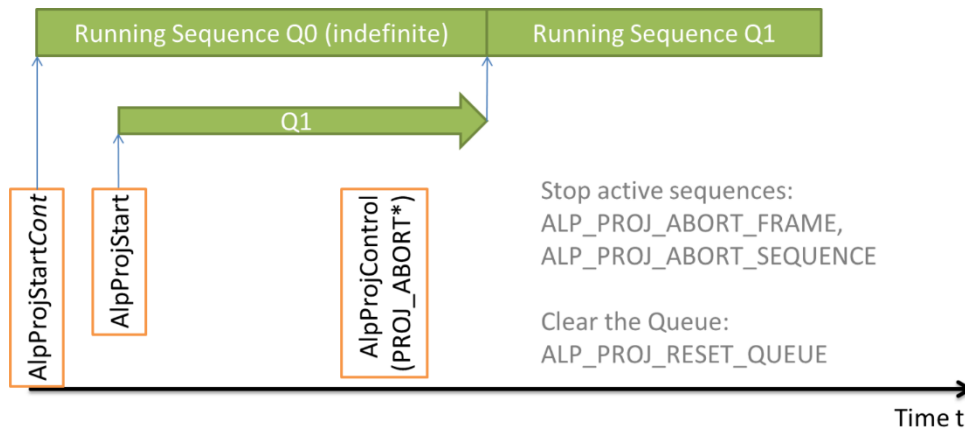

Two different abort requests are available: `ALP_PROJ_ABORT_SEQUENCE` finishes the current iteration of a sequence and stops. The other one, `ALP_PROJ_ABORT_FRAME`, stops after the next frame.

In both cases, the sequence stops synchronously. A complete frame is displayed and if there is a waiting sequence then it is started according to its timing setup after completion of *PictureTime*. In contrast to that, *AlpDevHalt* would abort everything asynchronously. Frame display is interrupted and the DMD is cleared immediately, and all waiting sequences are removed.

There exists a race condition when the sequence to be aborted is not running continuously. It could happen that the sequence has already regularly finished, i.e. after `ALP_SEQ_REPEAT` iterations, before the abort request actually arrives in the ALP device. In order to not accidentally abort the next sequence, the ALP API allows specifying the *QueueID* as *ControlValue*. If it is `ALP_DEFAULT`, then the currently running sequence is stopped, whichever it exactly is. If *ControlValue* is a valid *QueueID* then the abort request stays pending until the addressed active sequence runs.

This obviously means that not only the *running* sequence, but also a *waiting* sequence can be addressed to be aborted. Because there can be only one abort request pending at any given time, the *AlpProjControl* function returns `ALP_NOT_IDLE` if another sequence shall be aborted in the meantime.

Consequently, it is not allowed to abort a sequence that is waiting after any continuous sequence, because this would prohibit aborting it and make the continuous sequence run infinitely. If this malicious behavior is attempted then *AlpProjControl* returns `ALP_PARM_INVALID` to avoid deadlocks.

The same race condition as mentioned above could invalidate a previously valid *QueueID*. The sequence could just have been regularly finished. The ALP API cannot determine this condition in all cases, so *AlpProjControl* returns `ALP_OK` when *ControlValue* is not a valid *QueueID*.

Besides stopping a running sequence, it could also be required to clear the queue. The *AlpProjControl ControlType* `ALP_PROJ_RESET_QUEUE` removes all waiting sequences from the queue without affecting the running sequence.

Inquire Progress of Active Sequences

Once started ALP executes all sequences in the queue without any USB interaction. This concurrency of execution is a natural impact of the real-time requirements of ALP. But sometimes it is required to synchronize the program running in the computer with the ALP.

The most basic form of synchronization is waiting for a certain condition. The ALP API function *AlpProjWait* allows blocking while the ALP device is busy executing active sequences. In Sequence Queue Mode the queue can be operated concurrently by means of activating or aborting sequences, for example.

Warning: if waiting for a continuous sequence, without having another thread to abort it, then the thread dead-locks (waits endless). Because of that the ALP_PROJ_LEGACY mode forbids any calls to *AlpProjWait* while running a continuous sequence.

A more sophisticated synchronization method is supervision of sequence progress. The ALP API function *AlpProjInquireEx* with *InquireType* ALP_PROJ_PROGRESS returns detailed information to the user. Note that due to the nature of the inquiry over USB, the result is already “out-of-date” by maybe a few milliseconds. The following details are filled into a structure of type *tAlpProjProgress*:

QueueID and SequenceID of the running sequence – note that multiple active sequences (*AlpProjStart[Cont]*, ALP_PROJ_QUEUE_ID) can be started from the same *SequenceID* (created by *AlpSeqAlloc*)

nWaitingSequences – fill level of the queue, same as ALP_PROJ_QUEUE_MAX_AVAIL-ALP_PROJ_QUEUE_AVAIL

nSequenceCounter – Number of iterations left after the current one, according to ALP_SEQ_REPEAT. This counter starts at ALP_SEQ_REPEAT-1 and counts down to 0.

nFrameCounter – Number of frames left in the current sequence iteration. This counter starts at *nFramesPerSubSequence*-1 and counts down to 0 in each sequence repetition.

nSequenceCounterUnderflow – useful for continuous sequences. Sequences started by *AlpProjStartCont* have an initial Sequence Counter of $2^{20}-1=1048575$. It counts down, and restarts after *reaching* value 0. At this time the Underflow flag is set to denote that the Frame Counter is not reliable any more due to one or more underflows. The *nSequenceCounterUnderflow* starts at value 0 and then steps to the number of completed iterations before underflow (2^{20}).

PictureTime and *nFramesPerSubSequence* – These values are returned for convenience. They shall simplify the estimation of the time it still takes for the sequence to complete. Note that the sequence parameters may have already been changed (*AlpSeqControl*, *AlpSeqTiming*) since *AlpProjStart*. Hence the active sequence has settings which differ from values returned by *AlpSeqInquire*. Furthermore, inquiry of *nFramesPerSubSequence* is much easier than determining it from the different settings it depends on (Scrolling settings, FrameLUT).

Flags summarize other values and reveal additional details. They are bit-wise combined, so a binary “and” must be used to determine which flags are set. The following four flags are available:

- ALP_FLAG_QUEUE_IDLE: there are currently no active sequences
- ALP_FLAG_SEQUENCE_INDEFINITE: the running sequence is started continuously
- ALP_FLAG_SEQUENCE_ABORTING: the running sequence is about to be aborted
- ALP_FLAG_FRAME_FINISHED: the last frame of a sequence has completed illumination, but *PictureTime* has not yet elapsed. This flag can only appear if there is no waiting sequence.

The ALP updates its counters after *IlluminateTime* of a frame. This could become noticeable if *PictureTime* is much longer than *IlluminateTime* (see also *AlpSeqTiming*).

Timing Details

The section *AlpSeqTiming* defines some of the events within on *PictureTime* interval as well as relation between subsequent frames. This applies within one sequence, but it is also useful to understand the timing of the first frame of a sequence related to the very last frame of the previous one.

If both sequences have the same timing settings, and of course the next one is already waiting when the first one finishes, then no glitches should happen.

If timing changes, then two constraints apply:

The “first” *PictureTime* expires completely before the “next” *PictureTime* interval starts.

A break of at least Δt_1 is required between both illuminations.

Especially if *SynchDelay* (ALP_MASTER mode) or *TriggerInDelay* (ALP_SLAVE mode) is reduced then the second condition could cause an extra break. Impacts of different settings can easily be understood using the pictures in the *AlpSeqTiming* section. For that purpose just join different *PictureTime* intervals together.

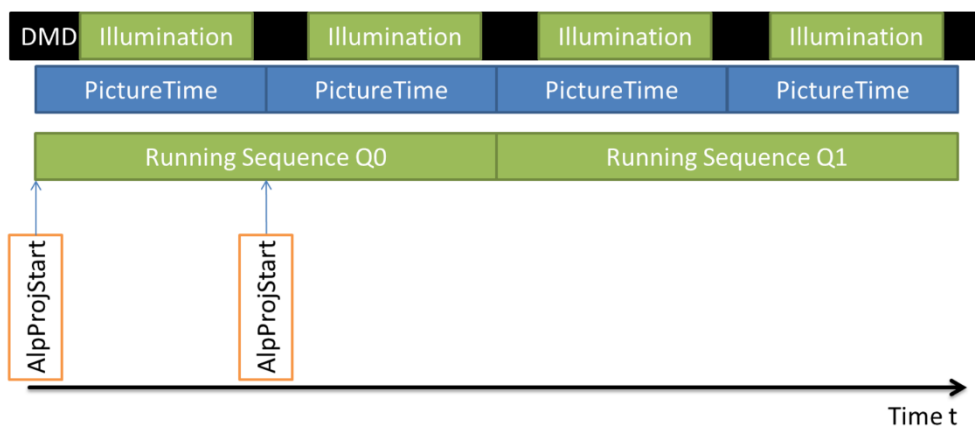

Legacy Mode Behavior

ALP_PROJ_LEGACY mode takes care that there is never more than one waiting sequence. Each time a sequence is activated, the previously waiting sequence is removed. Of course, this only happens when one sequence is running, making another one wait.

Additionally, this mode makes the active sequence start running within a finite time. If the current sequence runs an infinite number of iterations (started with *AlpProjStartCont*), then the API aborts it synchronously after the last frame of the current iteration.

Formally, *AlpProjStart* or *AlpProjStartCont* execute these commands in legacy mode:

1. ALP_PROJ_RESET_QUEUE
2. Enqueue the sequence
3. Query queue state, and if the running sequence is continuous (*AlpProjStartCont*):
ALP_PROJ_ABORT_SEQUENCE

In addition to these changes, the API also adjusts the *AlpProjWait* behavior. If the running or waiting sequence is continuous (*AlpProjStartCont*), then *AlpProjWait* rejects the call and returns ALP_PARM_INVALID. This avoids application dead-locks by waiting infinitely long.

3.7 Externally Triggered Frame Transition

The ALP-4 API supports an additional trigger mode. It allows frame display with internal timing (i.e. master mode) with conditional frame transitions. ALP repeats the display of each frame of a sequence until the trigger event is detected, causing the transition to the next frame.

The number of frame transitions is not changed by this mode. Settings like ALP_FIRSTFRAME, ALP_LASTFRAME, and ALP_SEQ_REPEAT still apply.

The trigger input port is Pin 7 of the Multi-Purpose I/O (Synchronization) connector (see V4100 Technical Reference Manual). This is the same as frame trigger input in ALP_SLAVE mode.

Related API Controls

The ALP_PROJ_STEP trigger mode is selected using *AlpProjControl* with *ControlType*=ALP_PROJ_STEP. The table below shows the meaning of different *ControlValues*.

ControlValue of ALP_PROJ_STEP	Description
ALP_DEFAULT	step forward after each displayed DMD frame
ALP_LEVEL_HIGH LOW	step forward if and only if the trigger input is high / low
ALP_EDGE_RISING FALLING	frame transition depends on a trigger edge

Interaction with other ALP settings

The ALP must be idle in order to switch ALP_PROJ_STEP trigger mode.

Use ALP_PROJ_STEP only with ALP_PROJ_MODE=ALP_MASTER.

Frame Lookup Table (FrameLUT): ALP_PROJ_STEP applies, conditionally stepping forward through the Lookup Table.

AlpProjHalt: The currently running sequence runs until all frames are displayed. This requires trigger events according to the ALP_PROJ_STEP setting.

Gated Frame Synchronization Outputs are not affected by ALP_PROJ_STEP. Their index counter progresses for each frame that is displayed on the DMD, even if it has the same image data.

Timing (Latency)

Frame Transition happens between $1*PictureTime+SynchDelay$ and $2*PictureTime+SynchDelay$ after the trigger edge.

ALP_LEVEL_* modes: hold the trigger constant at the start of SynchOut pulse $\pm 1\mu s$

ALP_EDGE_* modes: detected edges are stored internally; this memory is cleared each time when processing of the frame-transition starts, or when calling *AlpProjControl*(ALP_PROJ_STEP)

3.8 Flexible PWM Mode

The ALP-4 API supports an additional mode of displaying gray-scale sequences. In normal mode it assembles gray-scale values from bit planes using fixed weights. In ALP_FLEX_PWM mode, bit plane timing is controlled by a trigger input.

Related API Controls

A sequence must be allocated (*AlpSeqAlloc*) with the required number of *BitPlanes*. Then *AlpSeqControl* selects the ALP_FLEX_PWM mode. This implicitly switches the sequence to binary uninterrupted mode with fastest possible timing and zero *TriggerInDelay*.

Display order is: most-significant bit plane first.

AlpProjControl must be used to enable ALP_SLAVE mode. This way active trigger edges control the bit plane timing.

The new *ControlType* of *AlpSeqControl* is ALP_PWM_MODE. It can be used with *ControlValues* ALP_DEFAULT or ALP_FLEX_PWM.

ControlValue of ALP_PWM_MODE	Description
ALP_DEFAULT	Generate gray-scale display with internal timing using fixed bit-plane weights

ALP_FLEX_PWM	Process trigger edges to for bit-plane processing in order to implement custom weights
--------------	--

Interaction with other ALP settings

- Trigger edges and Synchronization pulses apply to bit planes rather than full gray-scale frames. A sequence of n Frames in normal mode displays n*BitNum binary frames in ALP_FLEX_PWM mode.
- Use ALP_FLEX_PWM only with ALP_PROJ_MODE=ALP_SLAVE.
- ALP_BIN_MODE is not available when a sequence is in ALP_FLEX_PWM mode. It is fixed ALP_BIN_UNINTERRUPTED.
- ALP_DEV_DYN_SYNCH_OUTx_GATE settings apply to bit-planes rather than gray-scale frames
- ALP_BITNUM is initially set to the number of sequence bit planes (ALP_BITPLANES)
- ALP_BITNUM can be used to reduce the number of bit planes. No additional AlpSeqTiming call is required in ALP_FLEX_PWM mode.
- Scrolling and ALP_FLUT_MODE can be combined with ALP_FLEX_PWM mode
- AlpSeqTiming can be used for adjusting TriggerInDelay and others. It is recommended to use the minimum possible PictureTime. It can be inquired using AlpSeqInquire(ALP_MIN_PICTURE_TIME)
- When leaving ALP_FLEX_PWM mode (set ALP_PWM_MODE=ALP_DEFAULT), an additional AlpSeqTiming call is necessary to make the change effective.

If ALP_BITPLANES exceeds gray-scale display capabilities then ALP_BITNUM is reduced automatically when leaving ALP_FLEX_PWM mode.

Gated Frame Synchronization Output

This ALP API extension handles additional features regarding management of multi-purpose pins. It also targets towards multi-color operation by the means of multiple synchronization outputs.

This ALP API adds 3 new logical signals: SYNCH_OUT1, SYNCH_OUT2, and SYNCH_OUT3. Each one of them can be configured to selectively output certain pulses of the SYNCH signal. This means that they share the same timing as the frame synchronization output (*SynchDelay*, *SynchPulseWidth*, see *AlpSeqTiming*), but stay inactive during frames for which they are deselected.

The function *AlpDevControlEx* has an input structure of type *tAlpDynSynchOutGate* and it supports control codes ALP_DEV_DYN_SYNCH_OUT1_GATE to ALP_DEV_DYN_SYNCH_OUT3_GATE. It configures the output based on circulating frame counters. Each of the output ports has one counter. The counters start counting with 0 at the first frame of a sequence after *AlpProjStart[Cont]*. After a counter reaches its maximum value (*Period-1*), it restarts at 0.

The indexes of the array *Gate* control the output at each state of the counter. Valid values are 0 for “stay inactive” and 1 meaning “output pulse”.

The signals are connected to the Multi-Purpose IO connector. See Pin assignment and default states for details.

Interactive Demo

Set up certain common scenarios (only dialogue elements!) Push the “Set” buttons afterwards!

Enable not checked: tAlpDynSynchOutGate::Period=0.

Enable checked: tAlpDynSynchOutGate::Period =number of “Gate Bits”

tAlpDynSynchOutGate::Polarity

tAlpDynSynchOutGate::Gate[0..n]

Set: Call AlpDevControlEx now.

(new settings apply only to new started sequences; if the ALP is idle then pin polarity changes immediately)

The ALP Demo serves as a good starting-point for understanding the behavior of this API extension. But it is highly recommended to develop a custom application using the API.

Example 1: Round Robin

A typical use case for dynamic gates is periodically enabling different light sources. This example pulses all three pins one after another and then restarts:

Pre-Condition: allocate device, allocate sequence, and download image data

```
// Set up the Gate for SYNCH_OUT1|2|3
```

```
tAlpDynSynchOutGate Gate;
```

```
ZeroMemory( &Gate, 18 ); // 18 = sizeof(tAlpDynSynchOutGate)
```

```
Gate.Period = 3;
```

```
Gate.Polarity = 1;
```

ALP-4.3 – Application Programming Interface

```
Gate.Gate[0] = 1;// the other "Gates" have already been initialized
to 0

AlpDevControlEx ( DeviceId, ALP_DEV_DYN_SYNCH_OUT1_GATE, &Gate );

// Period and Polarity stays the same, update Gate setting for
second port:

Gate.Gate[0] = 0; Gate.Gate[1] = 1;

AlpDevControlEx ( DeviceId, ALP_DEV_DYN_SYNCH_OUT2_GATE, &Gate );

// Update Gate setting for third port:

Gate.Gate[1] = 0; Gate.Gate[2] = 1;

AlpDevControlEx ( DeviceId, ALP_DEV_DYN_SYNCH_OUT3_GATE, &Gate );

// Start

AlpProjStart( DeviceId, SequenceId );
```

This source code complies with the following ALP Demo set up:

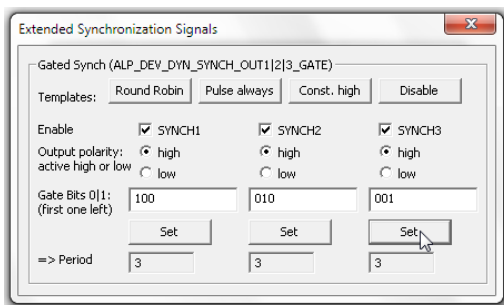

Given a sequence with *PictureTime*=200 μ s and 6 Frames to be displayed, the synchronization ports show the pulses as in the picture below. The frame synch output polarity is active-high.

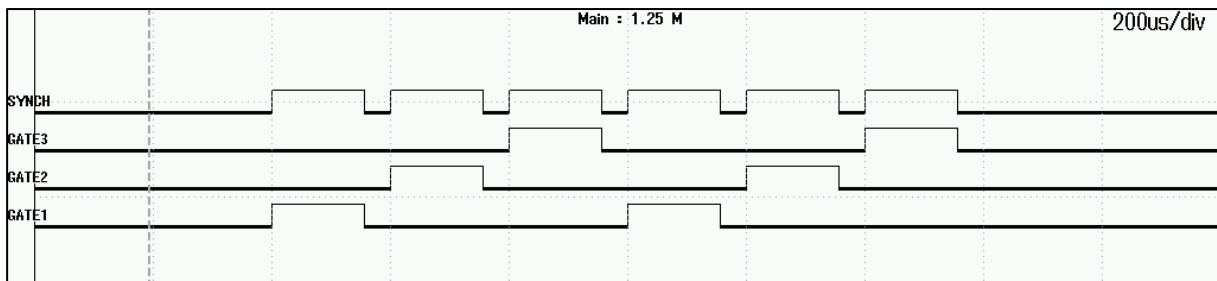

If the light-sources are enabled by an active-low signal, then simply change the source code above to `Gate.Polarity=0`. This results in signals shown in the next picture:

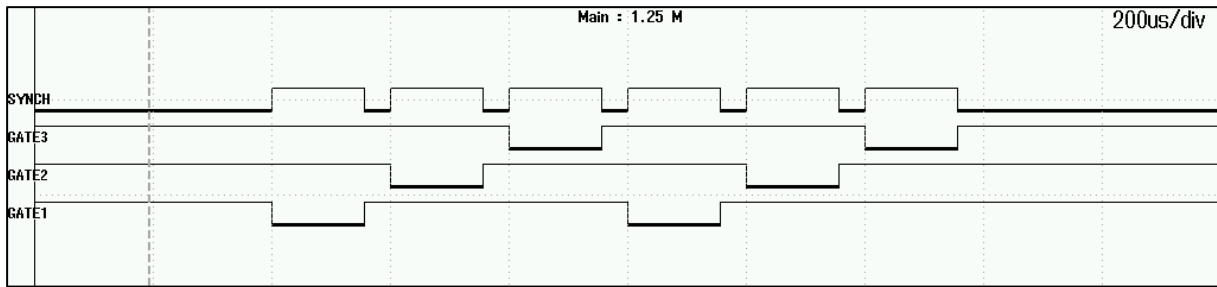

Example 2

All settings can be applied individually for all three synch outputs. This example uses Period=2, Gates=(1,0), Polarity=high for SYNCH_OUT1 and Period=3, Gates=(0,1,1), Polarity=low for SYNCH_OUT2:

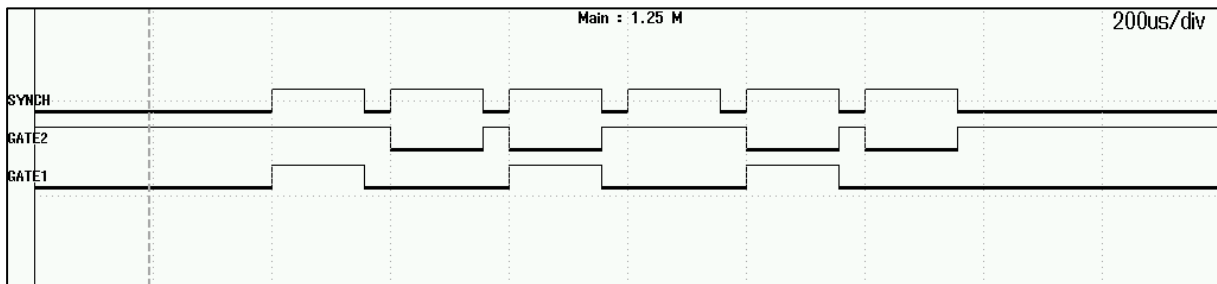
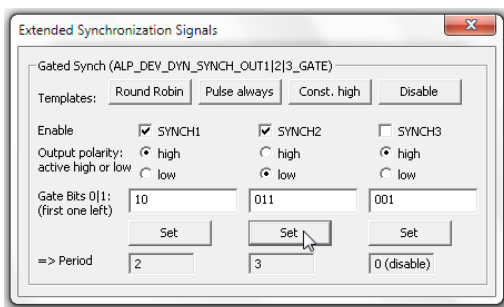

3.9 PWM Output

There are use cases when an analog signal is required, for example for controlling a light-source. V-Modules support this with a pulse-width modulated GPIO pin.

Use *AlpDevControl* with *ControlType* ALP_PWM_LEVEL in order to set up the duty-cycle (in percent).

PWM pulse period: fixed, 64 μ s

Accuracy: ± 2 % absolute

The PWM signal is connected to the Multi-Purpose IO connector. See

Pin assignment and default states for details.

3.10 Pin assignment and default states

Multi-Purpose IO connector pins are allocated to logical signals according to the fixed table below. Please refer to the hardware specific documents for electrical parameters (I/O Standard).

	Pin number	State after Power-Up	State after AlpDevAlloc	State after AlpDevFree
SYNCH_OUT1	Pin 2	Pull-Up 4,7 kΩ	constant low (no tri-state)	constant low (no tri-state)
SYNCH_OUT2	Pin 3	Pull-Up 4,7 kΩ	constant low (no tri-state)	constant low (no tri-state)
SYNCH_OUT3	Pin 4	Pull-Up 4,7 kΩ	constant low (no tri-state)	constant low (no tri-state)
PWM_LEVEL	Pin 9	Pull-Up 4,7 kΩ	0% (constant low)	0% (constant low)

3.11 USB Disconnect Handling

The ALP-4.3 API allows control over device behavior in USB disconnection scenarios.

3.11.1 Scenario

USB Disconnect refers to physically unplugging the USB cable of a V-Module. The same applies to cables of USB hubs implementing the link between computer and V-Module.

The device must be allocated in ALP-4.3 API (*AlpDevAlloc*) and it may execute sequence display (*AlpProjStart[Cont]*).

3.11.2 Default behaviour

When USB is disconnected:

- V-Module stops running sequences
- DLP chip is powered down
- On-board SDRAM (sequence memory) is preserved
- API functions that require device communication return ALP_DEVICE_REMOVED

After the USB link is restored, the behavior initially stays in the state as disconnected. This avoids undetected transients.

The application can use ALP_USB_CONNECTION (see also ALP-4.3 API description) to restore device and API state. All data is preserved, so sequences can be restarted afterwards.

3.11.3 Autonomous Mode

The ALP-4.3 API can make V-Modules continue DLP operation and running sequences. This can be done using the *AlpDevControl* function, *ControlType=ALP_USB_DISCONNECT_BEHAVIOUR*.

The default behavior is selected by setting `ALP_USB_DISCONNECT_BEHAVIOUR = ALP_USB_RESET`.

If `ALP_USB_DISCONNECT_BEHAVIOUR=ALP_USB_IGNORE`, then after USB disconnection:

- V-Module continues running sequences and DLP operation
- On-board SDRAM (sequence memory) is preserved
- API functions that require device communication return `ALP_DEVICE_REMOVED`
- Control and monitoring the device is not possible in this situation!

Applications that need to control ALP device after reconnection still have to use `ALP_USB_CONNECTION`. Note that this function resets a consistent device state, which includes stopping sequence display asynchronously. Sequence memory is preserved and display can be started instantly.

4 LED Control

4.1 Introduction to the ALP LED API

The ALP-4 API contains features for controlling the ViALUX high-power LED driver (HLD). This extension consists of API functions exported by the DLLs (`AlpLed...`), as well as control or inquire types and data structures.

The HLD must be connected to the I2C bus of the ALP device. Please refer to the “HLD-Connections” and to the “ALP-4.1 Connections” document or “V4100 Technical Reference” (ALP-4.2).

Users can manage even multiple LED drivers connected to a single ALP, set up the light intensity by means of the electrical current, and supervise the LED temperature. Please also consider the Gated Frame Synchronization Output for switching different LEDs on a frame-by-frame basis.

For convenience purpose an approach is implemented using a *Nominal Current* value and a relative *Brightness* value. The nominal value is represented in milliamps (mA) and brightness in percent. The HLD drives the $Nominal\ Current * Brightness / 100$.

Many of the supported LEDs contain an on-chip temperature sensor. Even though this sensor is placed next to the thermal source (LED junction), there is a temperature difference. The API estimates the actual junction temperature based on a model of the LED type and the measured value.

The following sections explain the ALP LED API functions. The ALP Demo (`AlpDemo.exe`) allows to interactively use these functions. This might be helpful for getting to know how to use them.

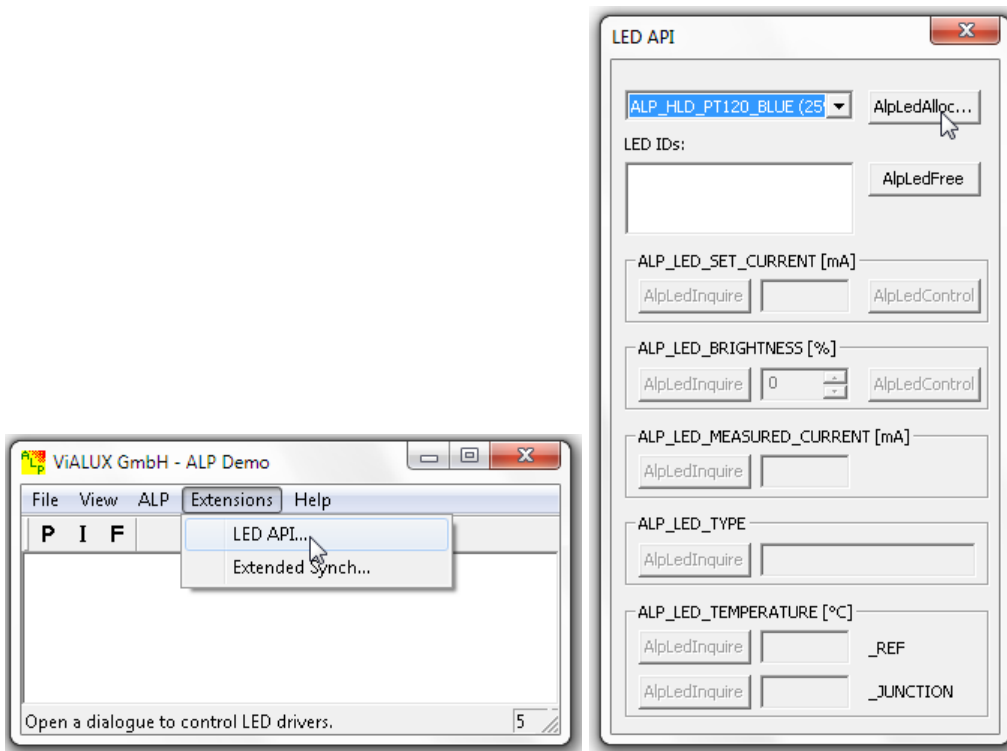

Note: Even custom light sources could be software-controlled by the PWM output pin of ALP. Please see PWM Output above.

4.2 AlpLedAlloc

Format

```
long AlpLedAlloc(ALP_ID DeviceId, long LedType, void *UserVarPtr, ALP_ID *LedIdPtr)
```

Description

AlpLedAlloc initializes and allocates a LED driver of the given type. It is addressed by its identifier LedId in subsequent ALP LED API calls.

Parameters

<i>DeviceId</i>	ALP device identifier
<i>LedType</i>	one of ALP_HLD_PT120_RED, ALP_HLD_PT120_GREEN, ALP_HLD_PT120_BLUE, ALP_HLD_PT120_390, or ALP_HLD_PT120_405 (see table below)
<i>UserVarPtr</i>	NULL or a pointer to structured data; the structure depends on <i>LedType</i> (see “Setting structures”).
<i>LedIdPtr</i>	address of a variable in which the ALP API stores the LED identifier; this number identifies the LED in subsequent API calls; it will be deleted by <i>AlpLedFree</i>

Compatible hardware

LedType	Compatible Hardware
ALP_HLD_PT120_RAX (2016 ⁶)	PT-120-RAX-L15, PT-121-RAX-L15
ALP_HLD_PT120_RED	PT-120-R-C11-MPB, PT-121-R-C11-MPB (obsolete since 2016, replaced by RAX type)
ALP_HLD_PT120_GREEN	PT-120-G-C11-MPB, PT-121-G-C11-MPB
ALP_HLD_PT120TE_BLUE	PT-121-B-L11
ALP_HLD_PT120_BLUE	PT-120-B-C11-EPA, PT-121-B-C11-EPA (obsolete, devices shipped since 2013 have the thermally enhanced TE package)
ALP_HLD_CBT90_WHITE	CBT-90-W*-C11
ALP_HLD_CBT140_WHITE	CBT-140-W*
ALP_HLD_CBT90_UV	CBT-90-UV
ALP_HLD_CBM120_UV365 (2016)	CBM-120-UV with maximum continuous current of 12A (wave length range between 365nm and 375nm)
ALP_HLD_CBM120_UV (2016)	CBM-120-UV with maximum continuous current of 18A (wave lengths 380nm and above)
ALP_HLD_CBT120_UV	CBT-120-UV

⁶ New in 2016; Old ALP API DLL do not yet support these LED types and return ALP_PARM_INVALID.

Setting structures

tAlpHldAllocParams

The *LedTypes* ALP_HLD_* use the structure tAlpHldAllocParams for *UserVarPtr*:

```

struct                tAlpHldAllocParams                {
long                  I2cDacAddr;
long                  I2cAdcAddr;
};

```

For HLD, the structure contains only bus addresses (I2C bus) of the LED driver. The structure can be omitted by passing a NULL pointer for *UserVarPtr*. In this case the ALP software scans the bus for a certain set of known addresses. The bus addresses are hard-wired on the HLD, so the order of returned devices is stable even without selecting certain addresses. It only varies when changing the set of HLD's that are connected to the ALP.

Valid settings for (I2cDacAddr, I2cAdcAddr) are (24, 64), (26, 66), (28, 68), and (30, 70).

Return values

The function can return one of the standard ALP API return codes. Please consider the additional hints below:

- ALP_PARM_INVALID is the result of an unsupported *LedType*
- ALP_ERROR_INIT: invalid *AllocParams*, or error initializing the LED driver
- ALP_NOT_ONLINE: when *UserStructPtr* = NULL and none of the known addresses works
- ALP_NOT_READY: one of the requested I2C addresses has already been allocated (e.g. a *LedId* for this device exists already)

4.3 AlpLedFree

Format

```
long AlpLedFree(ALP_ID DeviceId, ALP_ID LedId)
```

Description

The LED is switched off and the software object is released. *LedId* becomes unusable.

Parameters

<i>DeviceId</i>	ALP device identifier
<i>LedId</i>	LED identifier

4.4 AlpLedControl

Format

long AlpLedControl(ALP_ID DeviceId, ALP_ID LedId, long ControlType, long Value)

Description

Adjust the LED.

AlpLedControl allows to individually modify the nominal current (ALP_LED_SET_CURRENT) and the brightness (ALP_LED_BRIGHTNESS). This allows to easily use a percentage scale. Since the HLD's drive strength is adjusted immediately to the according product of both values, consider to dim the brightness before increasing the current.

Parameters

<i>DeviceId</i>	ALP device identifier
<i>LedId</i>	LED identifier
<i>ControlType</i>	control parameter that is to be modified
<i>Value</i>	value of the parameter

The following settings are available:

ControlType	Value	Description
ALP_LED_SET_CURRENT	ALP_DEFAULT (0)	Because the symbol ALP_DEFAULT has value 0, the LED is switched off. The initial value is only restored after <i>AlpLedAlloc</i> . Note: In former versions of the ALP API, ALP_DEFAULT had restored the drive current as specified for continuous operation for the given LED type.
	> 0	The value is interpreted as milliamps. The LED driver drives a current of $\text{Value} * \text{ALP_LED_BRIGHTNESS} / 100\%$.
ALP_LED_BRIGHTNESS	0	The LED is switched off. This is the default value after initialization.
	> 0	The value is interpreted as percentage. The LED driver drives a current of $\text{ALP_LED_SET_CURRENT} * \text{Value} / 100\%$. Value is allowed to become >100%.
ALP_LED_FORCE_OFF		There may be a small LED current remaining even after the HLD is set to 0 A. Use the enable-signal to guarantee that the LED stops emitting any light. Drawback of this approach is that re-starting the LED takes several milliseconds instead of microseconds. If speed is more crucial than residual light, then please set this parameter to ALP_LED_ON.
	ALP_LED_AUTO_OFF	(ALP_DEFAULT): The ALP LED API disables the LED if $\text{ALP_LED_SET_CURRENT} * \text{ALP_LED_BRIGHTNESS} / 100\% = 0$

ControlType	Value	Description
	ALP_LED_OFF	The LED is a disabled, independent of the brightness and current setting
	ALP_LED_ON	The LED stays enabled. Some residual light could be emitted even for current or brightness set to 0.

Return values

ALP_NOT_AVAILABLE: invalid DeviceId

ALP_PARM_INVALID: Value out of range (current*brightness/100% exceeds the capabilities of the LED type), invalid ControlType, or invalid LedId

ALP_ERROR_COMM: USB communication error or I2C bus error

4.5 AlpLedInquire

Format

long AlpLedInquire(ALP_ID DeviceId, ALP_ID LedId, long InquireType, long *UserVarPtr)

Description

This function measures a value or inquires a parameter setting.

The LED temperature (ALP_LED_TEMPERATURE_JUNCTION) is calculated from the measured value (ALP_LED_TEMPERATURE_REF) using a thermal model for the LED type. The thermal model depends on the currently driven LED current, so bear in mind that it might be inaccurate short after changing the drive current.

Parameters

DeviceId ALP device identifier

LedId LED identifier

InquireType specifies the ALP device parameter setting to inquire; See the table below.

UserVarPtr specifies the address of the variable in which the requested information is to be written. The variable must be of type long.

The *InquireType* supports the following values:

InquireType	Description
ALP_LED_TYPE	The <i>LedType</i> value used in AlpLedAlloc.
ALP_LED_SET_CURRENT	Milliamps: Nominal current.
ALP_LED_BRIGHTNESS	Percentage.
ALP_LED_FORCE_OFF	Additional method to disable residual LED current.

InquireType	Description
ALP_LED_MEASURED_CURRENT	Milliamps. The HLD measures the current it drives.
ALP_LED_TEMPERATURE_REF	1/256 °C: Measured temperature on the LED chip, near the LED junction.
ALP_LED_TEMPERATURE_JUNCTION	1/256 °C: Calculated temperature at the LED junction.

4.6 AlpLedControlEx

Format

```
long AlpLedControlEx(ALP_ID DeviceId, ALP_ID LedId, long ControlType,
void *UserStructPtr)
```

Description

This function is similar to AlpLedControl. However, it changes settings that do not fit into a scalar (long) value.

We have not yet defined any *ControlTypes* for AlpLedControlEx. It is prepared for future use.

Parameters

<i>DeviceId</i>	ALP device identifier
<i>LedId</i>	LED identifier
<i>ControlType</i>	control parameter that is to be modified
<i>UserStructPtr</i>	pointer to structured data; structure depends on <i>ControlType</i>

AlpLedInquireEx

Format

```
long AlpLedInquireEx(ALP_ID DeviceId, ALP_ID LedId, long InquireType,
void *UserStructPtr)
```

Description

This function is similar to AlpLedInquire. However, it returns data that do not fit into a scalar (long) value.

Parameters

<i>DeviceId</i>	ALP device identifier
<i>LedId</i>	LED identifier
<i>InquireType</i>	control parameter that is to be inquired

UserStructPtr pointer to structured data; structure depends on *InquireType*

InquireTypes and Data Structures

ALP_LED_ALLOC_PARAMS

UserStructPtr points to a data structure as in *AlpLedAlloc*, depending on *LedType*.

If the device has been automatically selected then this function can be used to inquire the actual set-up values.

5 Data types, Functions, Constants

The prototypes of all exported DLL functions are declared in the header file *alp.h*. This file also contains the values of symbolic constants like control types, return values etc.

Most C/C++ programmers will only require to `#include "alp.h"`. When using other programming languages, then please use the next sections as a quick reference.

5.1 Data types

The ALP API uses these data types, with 1 byte being 8 bits:

- Long (4-byte signed integer)
- ALP_ID (4-byte unsigned integer)
- Char (1-byte integer)
- Void (wild card – the actual type is defined by another setting or parameter value)

Data structures additional to standard ALP API data types:

Type (size in bytes), Function	Member data type (size)	Member (byte offset)
tAlpHidPt120AllocParams (8), <i>AlpLedAlloc, AlpLedInquireEx</i>	long (4)	I2cDacAddr (0)
	long (4)	I2cAdcAddr (4)
tAlpDynSynchOutGate (18), <i>AlpDevControlEx</i>	unsigned char (1)	Period (0)
	unsigned char (1)	Polarity (1)
	unsigned char array (16)	Gate (2)
tFlutWrite (up to 8+ 4*ALP_FLUT_MAX_ENTRIES9), <i>AlpProjControlEx</i>	long (4)	nOffset (0)
	long (4)	nSize (4)
	long array (4*nSize)	FrameNumbers (8)
tAlpLinePut (20), <i>AlpDevControlEx</i>	long (4)	TransferMode (0)
	long (4)	PicOffset (4)

Type (size in bytes), Function	Member data type (size)	Member (byte offset)
	long (4)	PicLoad (8)
	long (4)	LineOffset (12)
	long (4)	LineLoad (16)
tAlpProjProgress (36), AlpProjInquireEx	ALP_ID (4)	CurrentQueueId (0)
	ALP_ID (4)	SequenceId (4)
	unsigned long (4)	nWaitingSequences (8)
	unsigned long (4)	nSequenceCounter (12)
	unsigned long (4)	nSequenceCounterUnderflow (16)
	unsigned long (4)	nFrameCounter (20)
	unsigned long (4)	nPictureTime (24)
	unsigned long (4)	nFramesPerSubSequence (28)
	unsigned long (4)	nFlags (32)
tAlpDmdMask (8+nSize), AlpProjControlEx	long (4)	nRowOffset (0)
	long (4)	nRowCount (4)
	char array (nSize)	Bitmap (8)

5.2 List of Functions

The ALP DLL is available in different versions. They differ in calling convention (`_cdecl`, `_stdcall`) and target CPU (32-bit, 64-bit).

The exported function names are not decorated in order to achieve portability.

All functions return a 4-byte integer value. Pointer sizes depend on the target CPU: 4-byte pointers for 32-bit DLLs and 8-byte pointers for the 64-bit DLL. The following functions are available:

Function	Parameters
AlpDevAlloc	DeviceNum: 4-byte integer, InitFlag: 4-byte integer, DeviceIdPtr: pointer to a writable 4-byte integer
AlpDevControl	DeviceId: 4-byte integer, ControlType: 4-byte integer, ControlValue: 4-byte integer

ALP-4.3 – Application Programming Interface

Function	Parameters	
AlpDevInquire	Deviceld: InquireType: UserVarPtr:	4-byte integer, 4-byte integer, pointer to a writable 4-byte integer
AlpDevControlEx	Deviceld: ControlType: UserStructPtr:	4-byte integer, 4-byte integer, pointer to a read-able structure according to ControlType
AlpDevHalt	Deviceld:	4-byte integer
AlpDevFree	Deviceld:	4-byte integer
AlpSeqAlloc	Deviceld: BitPlanes: PicNum: SequenceldPtr:	4-byte integer, 4-byte integer, 4-byte integer, pointer to a writable 4-byte integer
AlpSeqControl	Deviceld: Sequenceld: ControlType: ControlValue:	4-byte integer, 4-byte integer, 4-byte integer, 4-byte integer
AlpSeqTiming	Deviceld: Sequenceld: IlluminateTime: PictureTime: SynchDelay: SynchPulseWidth: TriggerInDelay:	4-byte integer, 4-byte integer, 4-byte integer, 4-byte integer, 4-byte integer, 4-byte integer, 4-byte integer
AlpSeqInquire	Deviceld: Sequenceld: InquireType: UserVarPtr:	4-byte integer, 4-byte integer, 4-byte integer, pointer to a writable 4-byte integer
AlpSeqPut	Deviceld: Sequenceld: PicOffset: PicLoad: UserArrayPtr:	4-byte integer, 4-byte integer, 4-byte integer, 4-byte integer, pointer to a readable image data buffer; see also AlpSeqPut
AlpSeqPutEx	Deviceld: Sequenceld: UserStructPtr: PicLoad: UserArrayPtr:	4-byte integer, 4-byte integer, pointer to a read-able structure; first member: TransferMode (e.g. tAlpLinePut) 4-byte integer, pointer to a readable image data buffer
AlpSeqFree	Deviceld: Sequenceld:	4-byte integer, 4-byte integer

ALP-4.3 – Application Programming Interface

Function	Parameters	
AlpProjControl	Deviceld:	4-byte integer, ControlType: 4-byte integer, ControlValue: 4-byte integer
AlpProjInquire	Deviceld:	4-byte integer, InquireType: 4-byte integer, UserVarPtr: pointer to a writable 4-byte integer
AlpProjControlEx	Deviceld:	4-byte integer, ControlType: 4-byte integer, UserStructPtr: pointer to a read-able structure according to ControlType
AlpProjInquireEx	Deviceld:	4-byte integer, InquireType: 4-byte integer, UserStructPtr: pointer to a write-able structure according to InquireType
AlpProjStart	Deviceld:	4-byte integer, Sequenceld: 4-byte integer
AlpProjStartCont	Deviceld:	4-byte integer, Sequenceld: 4-byte integer
AlpProjHalt	Deviceld:	4-byte integer
AlpProjWait	Deviceld:	4-byte integer
AlpLedAlloc	Deviceld:	4-byte integer, LedType: 4-byte integer, UserStructPtr: pointer to a readable structure according to LedType LedIdPtr: pointer to a writable 4-byte integer
AlpLedFree	Deviceld:	4-byte integer, LedId: 4-byte integer,
AlpLedControl	Deviceld:	4-byte integer, LedId: 4-byte integer, ControlType: 4-byte integer, ControlValue: 4-byte integer
AlpLedInquire	Deviceld:	4-byte integer, LedId: 4-byte integer, InquireType: 4-byte integer, UserVarPtr: pointer to a writable 4-byte integer
AlpLedControlEx	Deviceld:	4-byte integer, LedId: 4-byte integer, ControlType: 4-byte integer, UserStructPtr: pointer to a readable structure according to ControlType
AlpLedInquireEx	Deviceld:	4-byte integer, LedId: 4-byte integer, InquireType: 4-byte integer, UserStructPtr: pointer to a writable structure according to InquireType

5.3 Constant values

Special values

ALP_DEFAULT=0

ALP_ENABLE=1

ALP_INVALID_ID=ULONG_MAX (= $2^{32}-1$ = 4294967295)

Return values

- ALP_OK	= 0
- ALP_NOT_ONLINE	= 1001
- ALP_NOT_IDLE	= 1002
- ALP_NOT_AVAILABLE	= 1003
- ALP_NOT_READY	= 1004
- ALP_PARM_INVALID	= 1005
- ALP_ADDR_INVALID	= 1006
- ALP_MEMORY_FULL	= 1007
- ALP_SEQ_IN_USE	= 1008
- ALP_HALTED	= 1009
- ALP_ERROR_INIT	= 1010
- ALP_ERROR_COMM	= 1011
- ALP_DEVICE_REMOVED	= 1012
- ALP_NOT_CONFIGURED	= 1013
- ALP_LOADER_VERSION	= 1014
- ALP_ERROR_POWER_DOWN	= 1018
- ALP_DRIVER_VERSION	= 1019
- ALP_SDRAM_INIT	= 1020

Device Inquire and Control Types (AlpDevControl, AlpDevInquire)

- ALP_DEVICE_NUMBER	= 2000
- ALP_VERSION	= 2001
- ALP_AVAIL_MEMORY	= 2003
- ALP_SYNCH_POLARITY	= 2004
- ALP_LEVEL_HIGH	= 2006
- ALP_LEVEL_LOW	= 2007
- ALP_TRIGGER_EDGE	= 2005
- ALP_EDGE_FALLING	= 2008
- ALP_EDGE_RISING	= 2009
- ALP_DEV_DMDTYPE	= 2021
- ALP_DMDTYPE_XGA	= 1
- ALP_DMDTYPE_1080P_095A	= 3
- ALP_DMDTYPE_XGA_07A	= 4
- ALP_DMDTYPE_XGA_055X	= 6

ALP-4.3 – Application Programming Interface

- ALP_DMDDTYPE_WUXGA_096A	= 7
- ALP_DMDDTYPE_WQXGA_400MHZ_090A	= 8
- ALP_DMDDTYPE_WQXGA_480MHZ_090A	= 9
- ALP_DMDDTYPE_1080P_065A	= 10
- ALP_DMDDTYPE_1080P_065_S600	= 11
- ALP_DMDDTYPE_WXGA_S450	= 12
- ALP_DMDDTYPE_DLPC910REV	= 254
- ALP_DMDDTYPE_DISCONNECT	= 255
- ALP_USB_CONNECTION	= 2016
- ALP_DEV_DYN_SYNCH_OUT1_GATE	= 2023
- ALP_DEV_DYN_SYNCH_OUT2_GATE	= 2024
- ALP_DEV_DYN_SYNCH_OUT3_GATE	= 2025
- ALP_DDC_FPGA_TEMPERATURE	= 2050
- ALP_APPS_FPGA_TEMPERATURE	= 2051
- ALP_PCB_TEMPERATURE	= 2052
- ALP_DEV_DISPLAY_HEIGHT	= 2057
- ALP_DEV_DISPLAY_WIDTH	= 2058
- ALP_SEQ_DMD_LINES	= 2125
- ALP_PWM_LEVEL	= 2063
- ALP_DEV_DMD_MODE	= 2064
- ALP_DMD_RESUME	= 0
- ALP_DMD_POWER_FLOAT	= 1
- ALP_USB_DISCONNECT_BEHAVIOUR	= 2078
- ALP_USB_IGNORE	= 1
- ALP_USB_RESET	= 2

Sequence Inquire and Control Types (AlpSeqControl, AlpSeqInquire)

- ALP_BITPLANES	= 2200
- ALP_BITNUM	= 2103
- ALP_BIN_MODE	= 2104
- ALP_BIN_NORMAL	= 2105
- ALP_BIN_UNINTERRUPTED	= 2106
- ALP_PICNUM	= 2201
- ALP_FIRSTFRAME	= 2101
- ALP_LASTFRAME	= 2102
- ALP_FIRSTLINE	= 2111
- ALP_LASTLINE	= 2112
- ALP_LINE_INC	= 2113
- ALP_SCROLL_FROM_ROW	= 2123
- ALP_SCROLL_TO_ROW	= 2124
- ALP_SEQ_REPEAT	= 2100
- ALP_PICTURE_TIME	= 2203
- ALP_MIN_PICTURE_TIME	= 2211
- ALP_MAX_PICTURE_TIME	= 2213

- ALP_ILLUMINATE_TIME	= 2204
- ALP_MIN_ILLUMINATE_TIME	= 2212
- ALP_ON_TIME	= 2214
- ALP_OFF_TIME	= 2215
- ALP_SYNCH_DELAY	= 2205
- ALP_MAX_SYNCH_DELAY	= 2209
- ALP_SYNCH_PULSEWIDTH	= 2206
- ALP_TRIGGER_IN_DELAY	= 2207
- ALP_MAX_TRIGGER_IN_DELAY	= 2210
- ALP_DATA_FORMAT	= 2110
- ALP_DATA_MSB_ALIGN	= 0
- ALP_DATA_LSB_ALIGN	= 1
- ALP_DATA_BINARY_TOPDOWN	= 2
- ALP_DATA_BINARY_BOTTOMUP	= 3
- ALP_SEQ_PUT_LOCK	= 2119
- ALP_FLUT_MODE	= 2118
- ALP_FLUT_NONE	= 0
- ALP_FLUT_9BIT	= 1
- ALP_FLUT_18BIT	= 2
- ALP_FLUT_ENTRIES9	= 2120
- ALP_FLUT_OFFSET9	= 2122
- ALP_PWM_MODE	= 2107
- ALP_FLEX_PWM	= 3
- ALP_DMD_MASK_SELECT	= 2134
- ALP_DMD_MASK_16X16	= 1
- ALP_DMD_MASK_16X8	= 2
- ALP_SEQ_DMD_LINES	= 2125

Projection Inquire and Control Types (AlpProjControl[Ex], AlpProjInquire[Ex])

- ALP_PROJ_MODE	= 2300
- ALP_MASTER	= 2301
- ALP_SLAVE	= 2302
- ALP_PROJ_STEP	= 2329
- ALP_PROJ_STATE	= 2400
- ALP_PROJ_ACTIVE	= 1200
- ALP_PROJ_IDLE	= 1201
- ALP_PROJ_INVERSION	= 2306
- ALP_PROJ_UPSIDE_DOWN	= 2307
- ALP_PROJ_QUEUE_MODE	= 2314
- ALP_PROJ_LEGACY	= 0
- ALP_PROJ_SEQUENCE_QUEUE	= 1
- ALP_PROJ_QUEUE_ID	= 2315
- ALP_PROJ_QUEUE_MAX_AVAIL	= 2316
- ALP_PROJ_QUEUE_AVAIL	= 2317

- ALP_PROJ_PROGRESS = 2318
- ALP_FLAG_QUEUE_IDLE = 1
- ALP_FLAG_SEQUENCE_ABORTING = 2
- ALP_FLAG_SEQUENCE_INDEFINITE = 4
- ALP_FLAG_FRAME_FINISHED = 8
- ALP_PROJ_RESET_QUEUE = 2319
- ALP_PROJ_ABORT_SEQUENCE = 2320
- ALP_PROJ_ABORT_FRAME = 2321
- ALP_PROJ_WAIT_UNTIL = 2323
- ALP_PROJ_WAIT_PIC_TIME = 0
- ALP_PROJ_WAIT_ILLU_TIME = 1
- ALP_FLUT_MAX_ENTRIES9 = 2324
- ALP_FLUT_WRITE_9BIT = 2325
- ALP_FLUT_WRITE_18BIT = 2326
- ALP_DMD_MASK_WRITE = 2339

AlpSeqPutEx TransferModes

- ALP_PUT_LINES = 1

LED Types

- ALP_HLD_PT120_RAX = 268
- ALP_HLD_PT120_RED = 257
- ALP_HLD_PT120_GREEN = 258
- ALP_HLD_PT120TE_BLUE = 263
- ALP_HLD_PT120_BLUE = 259
- ALP_HLD_CBT90_UV = 265
- ALP_HLD_CBM120_UV365 = 266
- ALP_HLD_CBM120_UV = 267
- ALP_HLD_CBT120_UV = 260
- ALP_HLD_CBT90_WHITE = 262
- ALP_HLD_CBT140_WHITE = 264

LED Inquire and Control Types (AlpLedControl, AlpLedInquire)

- ALP_LED_SET_CURRENT = 1001
- ALP_LED_BRIGHTNESS = 1002
- ALP_LED_FORCE_OFF = 1003
- ALP_LED_AUTO_OFF = 0
- ALP_LED_OFF = 1
- ALP_LED_ON = 2
- ALP_LED_TYPE = 1101
- ALP_LED_MEASURED_CURRENT = 1102
- ALP_LED_TEMPERATURE_REF = 1103
- ALP_LED_TEMPERATURE_JUNCTION = 1104

Extended LED Inquire and Control Types (AlpLedControlEx, AlpLedInquireEx)

- ALP_LED_ALLOC_PARAMS = 2101